

Jakarta
Semarang
Surabaya
Balikpapan



Product Catalog
2019 - 2020 *Version 3*



D

WELDING ACCESSORIES

Our Company

Established in 1968 as CV. Timur Raya, and later renamed to PT. Bumi Teknik Utama in 2004, with offices in Jakarta, Semarang, Surabaya, and Balikpapan. Our divisions are Welding Machines division, Welding Accessories division, Welding Consumable division, Tools & Power Tools division, Panel & Hand Tools, Retail division and Service & Support division.

In order to serve our customers better, we established Bumi Distribution Center in Cengkareng and we are planning to open more branches in different provinces and cities in the nationwide.

51 years of industrial experience and utilizing a strong backbone of the latest computerized system, such as online "SAP" ERP system, Business Intelligence and Bumi Intranet, give us the advantageous of fast working collaboration, knowledge, analyze and expertise that contributes greatly to the benefit of our customers.

As one of the fastest growing companies in the industry, we believe Human Capital is one of the company's main pillars. Which we pay lots of attention and investment in the recruitment and talent development program.

Our Customers : Metal Fabricators, Automotive Industry, Shipyard, Power Plant, Mechanical & Electrical, Oil, Gas, Mining and all related supporting Industries.

Our Products : High quality and reliable lifting, cutting, bevelling, grinding, welding, drilling, punching, bending, fastening and related products.



Our Vision : To be the leader in the professional industrial equipments by giving quality products and better after sales services.

Our Mission: To equip Our Customers with reliable, durable and efficient Professional Industrial Equipments. Together with preventive and corrective services that fulfill the needs and expectations of our customers and business partners.

Our Core values :

- Treating our customers with respect and faith.
- We grow through creativity, invention and innovation.
- We integrate honesty, discipline and commitment into all business aspects.

Stay connected with us :

 Website : www.bumi.info

 Youtube : [bumi.info](https://www.youtube.com/bumi.info)

 Facebook : [bumi.info jakarta](https://www.facebook.com/bumi.info.jakarta)
[bumi.info semarang](https://www.facebook.com/bumi.info.semarang)
[bumi.info surabaya](https://www.facebook.com/bumi.info.surabaya)
[bumi.info balikpapan](https://www.facebook.com/bumi.info.balikpapan)

 Instagram : [bumi.info](https://www.instagram.com/bumi.info)

 LinkedIn : [bumi.info](https://www.linkedin.com/company/bumi.info)

 Twitter : [bumi.info](https://twitter.com/bumi.info)



CONTENT

Group Name	Brand	Item Name	Current	Page
Automatic Welding Helmet	Kobewel	Welding Helmet		D 1
Welding Accessories	Trafimet	Plug and Socket		D 2
Welding Accessories	DACH	Torch Holder		D 2
Welding Accessories	DACH	Ground Clamps		D 2
Welding Accessories	Binzel	Gas Flow Meter & Spanner		D 2
Welding Accessories	Binzel	Electrode Holder		D 2
Gouging Torch	Kobewel	Gouging Torch G4 - 1000 A - 2.1 m / 7 feet		D 3
Anti Spatter	Siliconi	Welding Anti Spatter Spray & Paste		D 4 - D 5
Liquid Anti Spatter	Protec	Metallotion Protec CE 15 L at 5 ltr & 20 ltr		D 6
Gas Cutting Nozzle	Kobewel	Gas Cutting Nozzle		D 7
Gas Regulators	Kobewel	CO2 Fin Type, CO2 Heater, CO2, Argon, Acetylene, Oxygen, LPG		D 8
Premium Welding Cable	DACH	Premium Welding Cable		D 9
Cable Package	DACH	Plug to Socket		D 10
Cable Package	DACH	Plug to Electode Holder		D 10
Cable Package	DACH	Plug to Ground Clamp		D 10
Cable Package	DACH	Plug to Lug		D 10
Cable Package	DACH	Lug to Socket		D 11
Cable Package	DACH	Lug to Electrode Holder		D 11
Cable Package	DACH	Lug to Ground Clamp		D 11
Cable Package	DACH	Lug to Lug		D 11
Interpass Cable - KMD series	Kobewel	Interpass Cable - KMD series		D 12
Interpass Cable - KMX series	Kobewel	Interpass Cable - KMX series		D 13
Mig Gun - Air Cooled - Ergoplus 15	Trafimet	MIG Torch Ergoplus 15	150 A	D 14
Mig Gun - Air Cooled - Ergoplus 24	Trafimet	MIG Torch Ergoplus 24	250 A	D 15
Mig Gun - Air Cooled - Ergoplus 36	Trafimet	MIG Torch Ergoplus 36	340 A	D 16 - D 17
Mig Gun - Water Cooled - Ergoplus 500	Trafimet	MIG Torch Ergoplus 500	500 A	D 18 - D 19
Mig Gun - Water Cooled - Autoplus 500	Trafimet	MIG Torch Autoplus 500	500 A	D 20 - D 21
Mig Torch - Air Cooled - ABIMIG	Binzel	Abimig 350 S	350 A	D 22
Mig Torch - Air Cooled - ABIMIG	Binzel	Abimig 450 V	450 A	D 23
Mig Torch - Air Cooled - Industrial	Binzel	RB 61 GD	500 A	D 24
Mig Torch - Inner Shield	Binzel	Alpha Flux 350 S	330 A	D 25
Mig Torch - Liquid - Industrial	Binzel	MB 602	600 A	D 26
Robo Torch - Abirob	Binzel	Abirob 350 GC	350 A	D 27
Central Adaptor	DACH	Central Adaptor		D 28
Water Cooled Hose Package	DACH	Water Cooled Hose Package		D 29
Coolant	Trafimet	Coolant		D 30
TIG Torch	Trafimet	TIG Torches - Air Cooled - WP 9 V - 25 - 2	110 A	D 31
TIG Torch	Trafimet	TIG Torches - Air Cooled - WP 17 V - 25 - 2	140 A	D 32
TIG Torch	Trafimet	TIG Torches - Air Cooled - WP 26 V - 25 - 2	180 A	D 33
TIG Torch	Trafimet	TIG Torches - Air Cooled - Auto TIG 26	180 A	D 34
TIG Torch	Trafimet	TIG Torches - Air Cooled - SINTIG 17	140 A	D 35
TIG Torch	Trafimet	TIG Torches - Air Cooled - SINTIG 26	180 A	D 36
TIG Torch	Trafimet	TIG Torches - Water Cooled - SINTIG 18	320 A	D 37
TIG Torch	Trafimet	TIG Torches - Air Cooled - SINTIG 9	110 A	D 38
TIG Torch	Trafimet	TIG Torch - Water Cooled - SINTIG 20	250 A	D 39
TIG Torch	Trafimet	TIG Air Cooled Package	110 A	D 40
TIG Torch	DACH	TIG Torch - Air Cooled - WP 17 V - 25 - 2	150 A	D 41
TIG Torch	DACH	TIG Torch - Air Cooled - WP 26 V - 25 - 2	200 A	D 42
Tungsten Electrode	DACH	Tungsten		D 43
Tungsten Grinder	Neutrix	Tungsten Grinder - 240V-50/60HZ		D 44
Plasma Cutting Torch - Ergocut CB50	Trafimet	Plasma Cutting Torch - Ergocut CB50 - 6m - 1/4G	50 A	D 45
Plasma Cutting Torch - Ergocut A81	Trafimet	Plasma Cutting Torch - Ergocut A81 - 6m - 1/4G	80 A	D 46
Plasma Cutting Torch - Ergocut A151	Trafimet	Plasma Cutting Torch - Ergocut A151 - 6m - 1/4G	150 A	D 47
Plasma Cutting Torch - Ergocut P151	Trafimet	Plasma Cutting Torch - Ergocut P151 - 6m - 1/4G - Autocut P151	150 A	D 48
Plasma Cutting Torch	Binzel	PSB 31 HFS	30 A	D 49
Plasma Cutting Torch	Binzel	Abiplas Cut 70	70 A	D 50
Plasma Cutting Torch	Binzel	Abiplas Cut 110	110 A	D 51
Plasma Cutting Torch	Binzel	Abiplas Cut 150	150 A	D 52



Welding Helmet



Solarmatic Blue

Solarmatic Red

Solarmatic Green



Main applications

- Grinding
- Welding

Advantageous

- **The Most Reliable Switching** : The most reliable auto-darkening operation available. Filters work under the widest variety of lighting conditions and arc welding processes from low-amp TIG to high-amp plasma cutting. The filters switch reliably and quickly from both light-to-dark and dark-to-light for all types of welds : from short tack welds, to long production welds
- **Unsurpassed Optical Quality** : Filters have the highest industry rating for overall optical quality. The view is clear, undistorted, and sharp. Patented filter technology provides uniform shading across the entire viewing area. All filters have a Shade 4 light state, perfect for weld preparation, precision grinding, and maximum productivity
- Adjustable sensitivity function
- Adjustable delay time & UV / IR protection all the time

Specifications

Viewing Area	98 x 55 mm
Size of Cartridge	110 x 90 x 9 mm
Power Supply	Solar cells + Lithium Battery
Power on / off	Fully Automatic
Mode	Welding and Grinding
UV / IR Protection	Up to shade DIN 16 at all time
Light State	DIN 4
Shade	Adjustable from DIN 9 to 13
Sensitivity	Adjustable from low to high
Time Light to Dark	0.000030 Sec
Delay	Short - Middle - Long , 0.25 - 0.80 sec
Operating Temperature	- 5 up to 55 °C
Storing Temperature	20 up to 70 °C
Helmet Material	Polyamide
Total Weight	520 g



Adjustable button in the left side of helmet for delay time and shading



Adjustable button in the right side for Grinding/ welding mode and sensitivity

Item Code	Item Name	MoQ
201.22.009	Welding Helmet - Solarmatic Blue	1 Pc
201.22.010	Welding Helmet - Solarmatic Red	1 Pc
201.22.011	Welding Helmet - Solarmatic Green	1 Pc

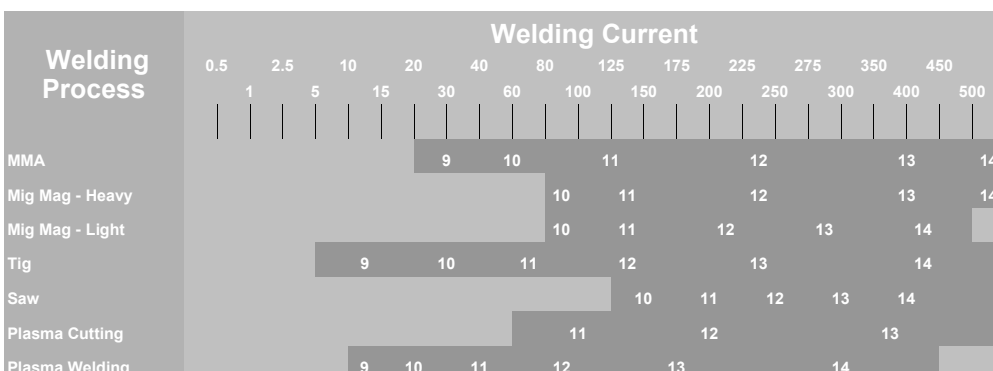



Welding Accessories

High quality welding accessories provide the best welding results

Item Code	Item Name	Ø	Max. Amp.	MoQ
203.01.008	Panel Socket - Standard - Trak-BE 35-70 mm	38 mm	400 A	2 Pcs



Item Code	Item Name	Ø	Max. Amp.	MoQ
203.01.009	Panel Socket - High - Trak-BE 35-70 mm	49 mm	400 A	2 Pcs



Item Code	Item Name	Ø	Max. Amp.	MoQ
203.01.001	Welding Cable Socket - Trak-BK 35 mm	21 mm	250 A	2 Pcs
203.01.002	Welding Cable Socket - Trak-BK 70 mm	21 mm	400 A	2 Pcs
203.01.003	Welding Cable Socket - Trak-BK 95 mm	24 mm	500 A	2 Pcs



Item Code	Item Name	Ø	Max. Amp.	MoQ
203.01.004	Welding Cable Plug - Trak-SK 10-25 mm	14 mm	200 A	2 Pcs
203.01.005	Welding Cable Plug - Trak-SK 35 mm	21 mm	250 A	2 Pcs
203.01.006	Welding Cable Plug - Trak-SK 70 mm	21 mm	400 A	2 Pcs
203.01.007	Welding Cable Plug - Trak-SK 95 mm	24 mm	500 A	2 Pcs



Item Code	Item Name	Ø	Max. Amp.	MoQ
203.01.010	Welding Connector - Plug & Socket 35 mm	21 mm	250 A	1 Set
203.01.011	Welding Connector - Plug & Socket 70 mm	21 mm	400 A	1 Set
203.01.012	Welding Connector - Plug & Socket 95 mm	24 mm	500 A	1 Set



Item Code	Item Name	MoQ
208.18.001	DACH Welding Torch Holder for TIG Torch	1 Pc
208.18.002	DACH Welding Torch Holder for MIG Torch	1 Pc



Item Code	Item Name	MoQ
208.16.002	DACH Ground Clamps, Capacity 300 Amps	1 Pc
208.16.003	DACH Ground Clamps, Capacity 400 Amps	1 Pc
208.16.004	DACH Ground Clamps, Capacity 600 Amps	1 Pc



Item Code	Item Name	MoQ
204.64.001	Binzel Flow Meter, Flow rate 0 up to 20 L/min	1 Pc



Item Code	Item Name	MoQ
201.39.001	Electrode Holder, 400 A	1 Pc
201.39.002	Electrode Holder, 600 A	1 Pc



Item Code	Item Name	MoQ
204.64.002	Binzel Multi Purpose Spanner for Mig Torch & Plasma Cutting Torch	1 Pc
204.64.003	Binzel Spanner for All Mig Torch	1 Pc





Gouging Torch G4 - 1000 A - 2.1 m / 7 feet



Advantageous

- Head assembly machined from copper alloy having four (4) air holes optimizing the air flow to the arc.
- Heavy duty insulators, lever and handle that are all made from fiberglass reinforced thermosed polyester molding compound to withstand the heat and be impact resistant.
- Kobewel G4 Torch work efficiently with the natural angles and movements of the arm and wrist.
- Highly efficient metal removal tools for fabrication jobs in steel fabrication plants, shipyards and heavy Industries.
- Speed up weld removal, backgouging, edge preparation, defect repair and many other metal removal jobs, with little or no deformation, because the heat input is so low.

Specifications

Rating	Max. 1.000 A
Air pressure	7 bar
Volume flow	Approx.0.60 m3/min
Connection air supply	13/8" - 18 NPT
Weight	1.20 kg (Working height 1m)

Item Code Item Name

MoQ

201.27.003 Gouging Torch G4 - 1000 A - 2.1 m / 7 feet 1 Set

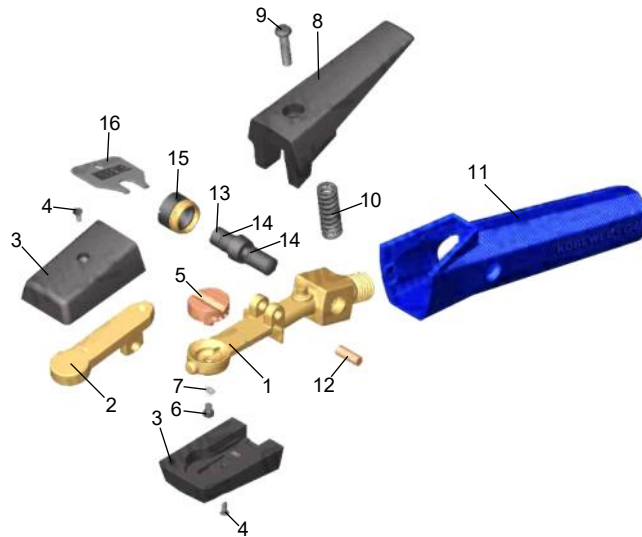

No.	Part Description	No.	Part Description
1	Torch Body, Kobewel G4	9	Lever Screw
2	Upper Arm	10	Lever Spring
3	Insulator	11	Handle
4	Insulator Screw	12	Hinge Pin
5	Head	13	Spool
6	Head Screw	14	Spool O-ring
7	Head Spring Washer	15	Bonnet
8	Lever	16	Bonnet Wrench



Anti Spatter

What is Anti Spatter ?

A chemical in the form of aerosol, liquid or paste used to protect workpieces, tables, jigs and fixtures from weld spatter buildup. The agent forms a barrier that makes spatter easy to remove after welding. The ideal anti-spatter agent is a non-toxic formula that is easy to remove; doesn't contaminate the weld seam; doesn't interfere with downstream processes such as priming, painting or galvanizing; and works well on a variety of materials. Using an anti spatter will prevent your workpiece from porosity

Main applications

- Welding
- Jig and Fixtures

Distac Weld Anti Spatter Spray Advantageous

Silicone-free anti spatter spray for metal. It is used as an anti-spatter with the piece to be welded and as a protector with the welding torch nozzles. Thanks to its composition free of silicone, it allows successive treatments as varnish, galvanization, chromium

Instructions for Use

Shake well before use. Spray the product around the pieces to be welded at a 25 cm distance.

Specifications

Appearance and colour	pressurized container with base and liquefied gas
Odour	characteristic
pH	neutral
Flammable point	<21 °C
Propellent autoignition temperature	287°C
Vapour pressure	3-5 bar
Solubility (water)	partial
Solubility (oil)	partial
Flammable	yes



Pasta Welding Anti Spatter Paste Advantageous

Protective paste formulated to protect the nozzles of the torches from the adhesion of the drops during the welding. It is a good antispatter, not flammable, not toxic and it has a long last durability.

Instructions for Use

Immerse the nozzle of the hot torch or the tip of the welding blowpipe into the pasta for few second, and then start to weld.

Specifications

Appearance and colour	Red Paste
Odour	odourless
pH	7 (sol. 5%)
Flammable Point	N.D.
Specific weight	0.9 g/ml (at 25 °C)
Vapour pressure	N.D.Kpa (at 20 °C)
Solubility (water)	No
Solubility (oil)	Yes
Flammable	No



Item Code	Item Name	Content	MoQ	Package
336.01.001	Antispatter Spray - Distac Weld 400 ml - Siliconi	400 ml	1 Pc	25 Pcs / Box
336.01.002	Antispatter Paste - Pasta Welding 300 gr - Siliconi	300 gr	1 Pc	12 Pcs / Box



Anti Spatter



What is Anti Spatter ?

A chemical in the form of aerosol, liquid or paste used to protect workpieces, tables, jigs and fixtures from weld spatter buildup. The agent forms a barrier that makes spatter easy to remove after welding. The ideal anti-spatter agent is a non-toxic formula that is easy to remove; doesn't contaminate the weld seam; doesn't interfere with downstream processes such as priming, painting or galvanizing; and works well on a variety of materials. Using an anti spatter will prevent your workpiece from porosity

Main applications

- Suitable for : Welding, Laser & Plasma Cutting
- Special for : Automatic welding machines

Ceramstak Anti Spatter Spray Advantageous

Is a good anti-spatter to protect the nozzle of the torch against the drops adhesion. It lasts many hours (until 8 hours) and it has a high anti-adhesive power superior to usual silicone free anti spatters because it resists to high temperatures. Ceramstak is also a good lubricant, it leaves a thin dry film, that improves the testing, prevents friction and reduces strain. It could be used to lubricate working tables, furnaces, foundry rails and whenever is required a dry lubricant for high temperatures.

Instructions for Use

Apply on clean surfaces to treat, dry and degrease well. Shake for 1 minute at least, during the application shake occasionally the product to keep it homogeneous. Spray it from 15 cm distance and deposit a thin film. After the use overturn the can and spray the product few second to dodge the obstruction of the valve. Self-life is 2 years from the production date.

Specifications

Odour	Typical (light petroleum products)
Flash point	< 0° C
Upper/lower flammability	15 Vol % - 1.8 Vol %
Vapour pressure	3-5 bar
Vapour density	2
Solubility (water)	Insoluble
Solubility (oil)	Soluble
Auto-ignition temperature	> 300° C
Explosive properties	Non explosive



Item Code	Item Name	Content	MoQ	Package
336.01.003	Antispatter Spray - Ceramstak 500 ml - Siliconi	500 ml	1 Pc	12 Pcs / Box



Metallotion Protec CE 15 L at 20 ltr



Referenced by Brands below



Characteristics

- METALLOTION PROTEC CE15L is a ready-to-use water based anti-spatter liquid against welding spatters which is sprayed on workpieces and moulds
- CE15L is efficient when wet and dry
- CE15L is a temporary corrosion protection
- Bio-welding & degreasing-lotion, ready-to-use, water based no silicones



Advantageous

- Minimization of costs and saving of time as no post treatment is necessary
- Higher quality by welds without pores and perfect metal surfaces
- Consumption savings of about 30 % compared with competitive products by improved spreading capacity
- Adhesion promoter for each type of surface technology
- METALLOTION PROTEC CE15L is tested and approved for welding, painting, electro-coating, powder-coating, galvanisation, zinc-coating
- Optimization of welding process
- CE15L is approved for automotive industry, vehicle industry, off-shore technology, container engineering, steel construction, crane industry, etc
- CE15L does not form pores during welding
- CE15L protects each metal surface and removes grease and oil at the same time, afterwards simple cleaning is sufficient
- CE15L is very economic and does not form residues

Specifications

Type of active substance	Vegetable fatty acid components with water emulsifiable
Density (20°C)	0.98 g/ml
Viscosity (40°C)	2.1 mm ² /s
Flash - point	na
Pour Point	-3° C
pH - value	7.1

Item Code	Item Name	MoQ
315.01.002.1	Metallotion Protec CE 15 L at 20 ltr	1 Pail





Gas Cutting Nozzle



Advantageous

- Quality gas cutting nozzle for accurate economical and safer cutting

Acetylene



Acetylene / A N M E			Pressure kg / cm ²		Consumption NI / hour			Cutting Speed mm / min
Item Code	No.	Plate thickness	Oxygen	Acetylene	Cutting Oxygen	Pre-heat Oxygen	Acetylene	
201.25.001	00	- 5	1.5	0.2	690	410	370	- 650
201.25.002	0	5 - 10	2.0	0.2	1.200	410	370	660 - 550
201.25.003	1	10 - 15	2.5	0.2	2.100	480	430	550 - 490
201.25.004	2	15 - 30	3.0	0.2	3.400	480	430	490 - 400
201.25.005	3	30 - 40	3.0	0.2	4.300	480	430	400 - 350
201.25.006	4	40 - 50	5.0	0.2	5.600	750	680	425 - 350
201.25.007	5	50 - 100	5.0	0.25	8.800	860	780	350 - 250

LPG



LPG / P N M E			Pressure kg / cm ²		Consumption NI / hour			Cutting Speed mm / min
Item Code	No.	Plate thickness	Oxygen	LPG	Cutting Oxygen	Pre-heat Oxygen	LPG	
201.25.008	00	- 5	1.5	0.2	690	1.180	310	- 650
201.25.009	0	5 - 10	2.0	0.2	1.200	1.180	310	660 - 550
201.25.010	1	10 - 15	2.5	0.2	2.100	1.180	310	550 - 490
201.25.011	2	15 - 30	3.0	0.25	3.400	1.370	360	490 - 400
201.25.012	3	30 - 40	3.0	0.25	4.300	1.370	360	400 - 350
201.25.013	4	40 - 50	3.5	0.3	6.500	1860	490	350 - 320
201.25.014	5	50 - 100	4.0	0.3	11.000	1860	490	320 - 200



Gas Regulator



Advantageous

- Kobewel medium duty regulators can be used for all industrial applications, where the need to read pressure on cylinder and working flow is required.
- Compact structure and economical
- Safety design with safety valve, against over pressurization
- Easy to read gauge scaling and covered with unbreakable lexan lens
- Applicable for wide welding and cutting applications
- Chromed forged brass body for maximum strength
- Sintered metal filter to trap impurities
- No soldered parts for easy maintenance



Specifications	Argon	CO2	CO2 Heater	CO2 Fin Type
High Pressure Gauge	5.000 psi	5.000 psi	5.000 psi	5.000 psi
Low Pressure Gauge	-	-	-	-
Flow Range	0 - 30 l/min	0 - 30 l/min	0 - 25 l/min	0 - 30 l/min
Input Voltage	-	-	220 volt	-
Power Consumption	-	-	190 watts	-



Specifications	Oxygen	Acetylene	LPG
High Pressure Gauge	4.500 psi	580 psi	580 psi
Low Pressure Gauge	220 psi	35 psi	35 psi
Flow Range	0 - 500 l/min	0 - 150 l/min	0 - 150 l/min
Input Voltage	-	-	-
Power Consumption	-	-	-

Item Code	Item Name	MoQ
201.23.001	Argon Gas Regulator	1 Pc
201.23.002	CO2 Gas Regulator	1 Pc
201.23.003	CO2 Heater 220V Gas Regulator	1 Pc
201.23.004	CO2 Fin Type Gas Regulator	1 Pc
201.23.006	Oxygen Gas Regulator	1 Pc
201.23.007	Acetylene Gas Regulator	1 Pc
201.23.008	LPG Gas Regulator	1 Pc



Premium Welding Cable



Advantageous

- DACH premium welding cable is designed to provide the optimum combination of flexibility & strength
- Very fine 0.19 mm copper wires are used to construct a flexible conductor that complies with all international standards. A double insulation system is then extruded over the conductor to provide electrical strength and durability.
- The outer sheath is a specially formulated Synthetic Rubber compound that resists oils, solvents, ozone, sea-water and prolonged ultraviolet exposure. Furthermore, the bright orange sheath does not sustain combustion and self-extinguish immediately upon removal of the flame sources.
- Meter marking, every meter along the cable, a descending number is printed indicating the balance of cable remaining. This not only provides a guarantee on the correct cable quantity, but also very useful for stock-takes and issuing of cable to customers.

Specifications

Conductor	Plain Annealed Copper wire
Insulation	PVC 90 °C , White color
Sheath	NBR 90 °C , Orange color
Voltage	600 / 1000 Volts
Standards	AS 3147, AS 1995, IEC 245-6

Cable	Duty Cycle			
	100 %	60 %	30 %	20 %
35 mm ²	195 A	250 A	355 A	440 A
50 mm ²	250 A	320 A	450 A	560 A
70 mm ²	310 A	400 A	560 A	690 A
95 mm ²	380 A	480 A	680 A	830 A
120 mm ²	435 A	560 A	785 A	960 A

Item Code	Cable	Packaging	Overall	Approx. Weight	Approx. Weight	DC Resistance	
Roll	Retail	In Roll	Diameter	per 50 m	per 100 m	per 100 m	
208.13.013	208.13.006	35 mm ²	100 m	13.5 mm	-	40 Kg	0.530 Ω
208.13.014	208.13.007	50 mm ²	100 m	15.0 mm	-	55 Kg	0.375 Ω
208.13.015	208.13.008	70 mm ²	100 m	17.5 mm	-	78 Kg	0.267 Ω
208.13.016	208.13.009	95 mm ²	50 m	19.5 mm	49 Kg	-	0.198 Ω
208.13.017	208.13.010	120 mm ²	50 m	21.5 mm	57 Kg	-	0.161 Ω
208.13.011	-	95 mm ²	100 m	19.5 mm	-	96 Kg	0.198 Ω
208.13.012	-	120 mm ²	100 m	21.5 mm	-	113 Kg	0.161 Ω



Plug to Socket - Cable Package						
Cable Size	3m	5m	10 m	20m	30m	MoQ
35 mm2	-	208.02.013	208.02.014	-	-	1 Set
50 mm2	208.02.009	208.02.010	208.02.011	208.02.012	-	1 Set
70 mm2	208.02.004	208.02.005	208.02.006	208.02.007	208.02.008	1 Set
95 mm2	-	-	208.02.001	208.02.002	208.02.003	1 Set



Plug to Electrode Holder - Cable Package							
Cable Size	EH Amperage	5m	10 m	20m	25 m	30m	MoQ
35 mm2	400 A	208.03.009	208.03.010	-	-	-	1 Set
50 mm2	400 A	208.03.005	208.03.006	208.03.007	208.03.008	-	1 Set
70 mm2	600 A	208.03.001	208.03.002	208.03.003	-	208.03.004	1 Set



Plug to Ground Clamp - Cable Package					
Cable Size	GC Amperage	5m	10 m	15 m	MoQ
35 mm2	300 A	208.04.009	208.04.010	-	1 Set
50 mm2	600 A	208.04.007	208.04.008	-	1 Set
70 mm2	600 A	208.04.004	208.04.005	208.04.006	1 Set
95 mm2	600 A	208.04.001	208.04.002	208.04.003	1 Set



Plug to Lug - Cable Package		
Cable Size	0.25m	MoQ
50 mm2	208.05.003	1 Set
70 mm2	208.05.002	1 Set
95 mm2	208.05.001	1 Set



Lug to Socket - Cable Package		
Cable Size	0.25m	MoQ
50 mm ²	208.06.003	1 Set
70 mm ²	208.06.002	1 Set
95 mm ²	208.06.001	1 Set



Lug to Electrode Holder - Cable Package						
Cable Size	EH Amperage	5m	10 m	20m	30m	MoQ
35 mm ²	400 A	208.07.008	208.07.009	-	-	1 Set
50 mm ²	400 A	208.07.005	208.07.006	208.07.007	-	1 Set
70 mm ²	600 A	208.07.001	208.07.002	208.07.003	208.07.004	1 Set



Lug to Ground Clamp - Cable Package					
Cable Size	GC Amperage	5m	10 m	15 m	MoQ
35 mm ²	300 A	208.08.009	-	-	1 Set
50 mm ²	600 A	208.08.007	208.08.008	-	1 Set
70 mm ²	600 A	208.08.004	208.08.005	208.08.006	1 Set
95 mm ²	600 A	208.08.001	208.08.002	208.08.003	1 Set



Lug to Lug - Cable Package				
Cable Size	10m	20m	30m	MoQ
50 mm ²	208.09.007	208.09.008	-	1 Set
70 mm ²	208.09.004	208.09.005	208.09.006	1 Set
95 mm ²	208.09.001	208.09.002	208.09.003	1 Set



Interpass Cable - KMD Series



Item Code	Optional Interpass Cable for Kobewel Mig Mag KMD 285 size 50 mm2	MoQ
201.05.007	Interpass Cable size 50 mm at 10 m - Air Cooled	1 Set
201.05.008	Interpass Cable size 50 mm at 15 m - Air Cooled	1 Set
201.06.007	Interpass Cable size 50 mm at 10 m - Water Cooled	1 Set
201.06.008	Interpass Cable size 50 mm at 15 m - Water Cooled	1 Set

Item Code	Optional Interpass Cable for Kobewel Mig Mag KMD 352 size 50 mm2	MoQ
201.05.004	Interpass Cable size 50 mm at 10 m - Air Cooled	1 Set
201.05.005	Interpass Cable size 50 mm at 15 m - Air Cooled	1 Set
201.06.004	Interpass Cable size 50 mm at 10 m - Water Cooled	1 Set
201.06.005	Interpass Cable size 50 mm at 15 m - Water Cooled	1 Set

Item Code	Optional Interpass Cable for Kobewel Mig Mag KMD 352 size 70 mm2	MoQ
201.05.006	Interpass Cable size 70 mm at 20 m - Air Cooled	1 Set
201.06.006	Interpass Cable size 70 mm at 20 m - Water Cooled	1 Set

Item Code	Optional Interpass Cable for Kobewel Mig Mag KMD 502 size 70 mm2	MoQ
201.05.001	Interpass Cable size 70 mm at 10 m - Air Cooled	1 Set
201.05.002	Interpass Cable size 70 mm at 15 m - Air Cooled	1 Set
201.06.001	Interpass Cable size 70 mm at 10 m - Water Cooled	1 Set
201.06.002	Interpass Cable size 70 mm at 15 m - Water Cooled	1 Set

Item Code	Optional Interpass Cable for Kobewel Mig Mag KMD 502 size 95 mm2	MoQ
201.05.003	Interpass Cable size 95 mm at 20 m - Air Cooled	1 Set
201.06.003	Interpass Cable size 95 mm at 20 m - Water Cooled	1 Set

Interpass Cable - KMX Series



Item Code	Optional Interpass Cable for Kobewel Mig Mag KMX 352 size 50 mm2	MoQ
201.09.001	Interpass Cable size 50 mm at 10 m - Air Cooled	1 Set
201.09.002	Interpass Cable size 50 mm at 15 m - Air Cooled	1 Set
201.10.001	Interpass Cable size 50 mm at 10 m - Water Cooled	1 Set
201.10.002	Interpass Cable size 50 mm at 15 m - Water Cooled	1 Set

Item Code	Optional Interpass Cable for Kobewel Mig Mag KMX 352 size 70 mm2	MoQ
201.09.003	Interpass Cable size 70 mm at 20 m - Air Cooled	1 Set
201.10.003	Interpass Cable size 70 mm at 20 m - Water Cooled	1 Set

Item Code	Optional Interpass Cable for Kobewel Mig Mag KMX 502 size 70 mm2	MoQ
201.09.004	Interpass Cable size 70 mm at 10 m - Air Cooled	1 Set
201.09.005	Interpass Cable size 70 mm at 15 m - Air Cooled	1 Set
201.10.004	Interpass Cable size 70 mm at 10 m - Water Cooled	1 Set
201.10.005	Interpass Cable size 70 mm at 15 m - Water Cooled	1 Set

Item Code	Optional Interpass Cable for Kobewel Mig Mag KMX 502 size 95 mm2	MoQ
201.09.006	Interpass Cable size 95 mm at 20 m - Air Cooled	1 Set
201.10.006	Interpass Cable size 95 mm at 20 m - Water Cooled	1 Set



MIG Gun - Air Cooled - Ergoplus 15



Advantageous

- Interchangeable with the best-known European brands
- A sturdy torch that combines the qualities of compactness and light weight with great reliability
- Ergonomic handle
- Torch with ball joint to ease welding movement
- Attachments : Euro with mobile pins

Specifications

Rating	180 A for CO2
	150 A for Mixed Gases M 21
	60 % Duty Cycle
Wire sizes	0.6 - 1.0 mm



Pos	Item Code	Item Name	MoQ
1	203.02.006	Gas Nozzle Ø 12 mm - Ergoplus 15	5 Pcs / 10 Pcs
2	203.07.002	Contact Tip M6, Pure Copper E-Cu Ø 0.8 - Ergoplus 15	10 Pcs
	203.07.003	Contact Tip M6, Pure Copper E-Cu Ø 0.9 - Ergoplus 15	10 Pcs
	203.07.004	Contact Tip M6, Pure Copper E-Cu Ø 1.0 - Ergoplus 15	10 Pcs
3	203.02.005	Nozzle Spring - Ergoplus 15	5 Pcs / 10 Pcs
4	203.02.003	Gas Diffusor - Ergoplus 15	2 Pcs
5	203.02.004	Head Insulator - Ergoplus 15	5 Pcs
6	203.02.007	Torch Head - Ergoplus 15	1 Pc
9	203.13.002	Blue Insulated - Steel Liner - Wire Ø 0.6 - 0.9 mm at 4 m	1 Pc
10	203.13.004	Red Insulated - Steel Liner - Wire Ø 1.0 - 1.2 mm at 3 m	1 Pc
	203.13.005	Red Insulated - Steel Liner - Wire Ø 1.0 - 1.2 mm at 4 m	1 Pc
11	203.14.003	Blue Teflon Liner - for Aluminum Wire Ø 0.6 - 0.9 mm at 5 m	1 Pc
12	203.14.004	Red Teflon Liner - for Aluminum Wire Ø 1.0 - 1.2 mm at 3 m	1 Pc
	203.14.005	Red Teflon Liner - for Aluminum Wire Ø 1.0 - 1.2 mm at 4 m	1 Pc
13	203.14.010	Copper Liner - for Aluminum Wire up to 1.6 mm	1 Pc

Item Code	Item Name	MoQ
203.02.001	Mig Torch - Ergoplus 15 at 3 m long	1 Set
203.02.002	Mig Torch - Ergoplus 15 at 4 m long	1 Set
	• Contact Tip M6, E-Cu Ø 0.8 mm	
	• Contact tip M6, E-Cu Ø 0.9 mm	
	• Spanner mig accessory attached	



Recommended Anti Spatter for better Welding result



MIG Gun - Air Cooled - Ergoplus 24



Advantageous

- Interchangeable with the best-known European brands
- A sturdy torch that combines the qualities of compactness and light weight with great reliability
- Ergonomic handle
- Torch with ball joint to ease welding movement
- Attachments : Euro with mobile pins

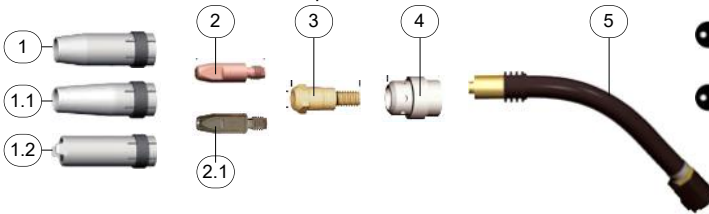

Specifications

Rating	250 A for CO2
	220 A for Mixed Gases M 21
	60 % Duty Cycle
Wire sizes	0.8 - 1.2 mm

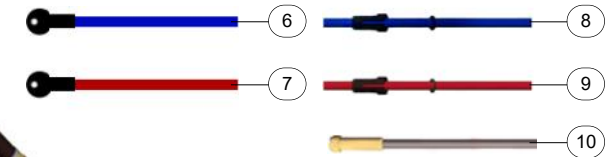

Pos	Item Code	Item Name	MoQ
1	203.03.006	Gas Nozzle - Conical Ø 12.5 mm - Ergoplus 24	5 Pcs / 10 Pcs
1.1	203.03.008	Gas Nozzle - Tapered Ø 10 mm - Ergoplus 24	5 Pcs / 10 Pcs
1.2	203.03.009	Gas Nozzle - Spot Weld Ø 17 mm - Ergoplus 24	5 Pcs / 10 Pcs
2	203.08.001	Contact Tip M6, Pure Copper E-Cu Ø 0.8 mm - Ergoplus 24 - 36 - 500	10 Pcs
	203.08.002	Contact Tip M6, Pure Copper E-Cu Ø 0.9 mm - Ergoplus 24 - 36 - 500	10 Pcs
	203.08.003	Contact Tip M6, Pure Copper E-Cu Ø 1.0 mm - Ergoplus 24 - 36 - 500	10 Pcs
	203.08.004	Contact Tip M6, Pure Copper E-Cu Ø 1.2 mm - Ergoplus 24 - 36 - 500	10 Pcs
2.1	204.20.002	Contact Tip M6, Silver Plated - Ø 0.9 mm - Ergoplus 24 - 36 - 500	10 Pcs
	204.20.003	Contact Tip M6, Silver Plated - Ø 1.0 mm - Ergoplus 24 - 36 - 500	10 Pcs
	204.20.004	Contact Tip M6, Silver Plated - Ø 1.2 mm - Ergoplus 24 - 36 - 500	10 Pcs
3	203.03.005	Tip Holder M6 - Ergoplus 24	5 Pcs / 10 Pcs
4	203.03.004	Gas diffuser white ceramic - Ergoplus 24	10 Pcs
5	203.03.007	Torch head - Ergoplus 24	1 Pc
6	203.13.002	Blue Insulated - Steel Liner - Wire Ø 0.6 - 0.9 mm at 4 m	1 Pc
	203.13.003	Blue Insulated - Steel Liner - Wire Ø 0.6 - 0.9 mm at 5 m	1 Pc
7	203.13.004	Red Insulated - Steel Liner - Wire Ø 1.0 - 1.2 mm at 3 m	1 Pc
	203.13.005	Red Insulated - Steel Liner - Wire Ø 1.0 - 1.2 mm at 4 m	1 Pc
	203.13.006	Red Insulated - Steel Liner - Wire Ø 1.0 - 1.2 mm at 5 m	1 Pc
8	203.14.003	Blue Teflon Liner - for Aluminum Wire Ø 0.6 - 0.9 mm at 5 m	1 Pc
9	203.14.004	Red Teflon Liner - for Aluminum Wire Ø 1.0 - 1.2 mm at 3 m	1 Pc
	203.14.005	Red Teflon Liner - for Aluminum Wire Ø 1.0 - 1.2 mm at 4 m	1 Pc
	203.14.006	Red Teflon Liner - for Aluminum Wire Ø 1.0 - 1.2 mm at 5 m	1 Pc
10	203.14.010	Copper Liner - for Aluminum Wire up to 1.6 mm	1 Pc

Item Code	Item Name	MoQ
203.03.001	Mig Torch - Ergoplus 24 at 3 m long	1 Set
203.03.002	Mig Torch - Ergoplus 24 at 4 m long	1 Set
203.03.003	Mig Torch - Ergoplus 24 at 5 m long	1 Set
	• Contact Tip M6, E-Cu Ø 1.2 mm - Ergoplus 24 - 36 - 500	
	• Spanner mig accessory attached	



Recommended Anti Spatter for better Welding result



MIG Gun - Air Cooled - Ergoplus 36



Advantageous

- Interchangeable with the best-known European brands
- A sturdy torch that combines the qualities of compactness and light weight with great reliability
- Ergonomic handle
- Torch with ball joint to ease welding movement
- Attachments : Euro with mobile pins

Specifications

Rating	340 A for CO2
	320 A for Mixed Gases M 21
	60 % Duty Cycle
Wire sizes	0.8 - 1.6 mm

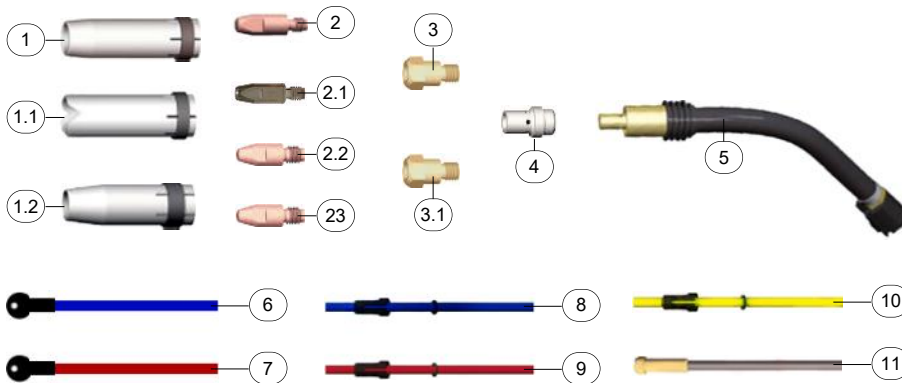

Pos	Item Code	Item Name	MoQ
1	203.04.007	Gas Nozzle Conical Ø 16 mm - L 84 mm - Ergoplus 36	2 Pcs / 10 Pcs
1.1	203.04.010	Gas Nozzle - Spot Weld Ø 20 mm - Ergoplus 36	2 Pcs / 10 Pcs
1.2	203.04.009	Gas Nozzle Tapered Ø 12 mm - Ergoplus 36	2 Pcs / 10 Pcs
2	203.08.001	Contact Tip M6, Pure Copper E-Cu Ø 0.8 mm - Ergoplus 24 - 36 - 500	10 Pcs
	203.08.002	Contact Tip M6, Pure Copper E-Cu Ø 0.9 mm - Ergoplus 24 - 36 - 500	10 Pcs
	203.08.003	Contact Tip M6, Pure Copper E-Cu Ø 1.0 mm - Ergoplus 24 - 36 - 500	10 Pcs
	203.08.004	Contact Tip M6, Pure Copper E-Cu Ø 1.2 mm - Ergoplus 24 - 36 - 500	10 Pcs
	203.08.005	Contact Tip M6, Pure Copper E-Cu Ø 1.6 mm - Ergoplus 24 - 36 - 500	10 Pcs
2.1	204.20.002	Contact Tip M6, Silver Plated - Ø 0.9 mm - Ergoplus 24 - 36 - 500	10 Pcs
	204.20.003	Contact Tip M6, Silver Plated - Ø 1.0 mm - Ergoplus 24 - 36 - 500	10 Pcs
	204.20.004	Contact Tip M6, Silver Plated - Ø 1.2 mm - Ergoplus 24 - 36 - 500	10 Pcs
2.2	203.09.001	Contact Tip M8, Pure Copper E-Cu Ø 1.0 mm - Ergoplus 36 - 500	10 Pcs
	203.09.002	Contact Tip M8, Pure Copper E-Cu Ø 1.2 mm - Ergoplus 36 - 500	10 Pcs
	203.09.003	Contact Tip M8, Pure Copper E-Cu Ø 1.4 mm - Ergoplus 36 - 500	10 Pcs
	203.09.004	Contact Tip M8, Pure Copper E-Cu Ø 1.6 mm - Ergoplus 36 - 500	10 Pcs
2.3	203.10.001	Contact Tip M8, Copper Chromium Zirconium CuCrZr Ø 1.0 mm - Ergoplus 36 - 500	10 Pcs
	203.10.002	Contact Tip M8, Copper Chromium Zirconium CuCrZr Ø 1.2 mm - Ergoplus 36 - 500	10 Pcs
	203.10.003	Contact Tip M8, Copper Chromium Zirconium CuCrZr Ø 1.4 mm - Ergoplus 36 - 500	10 Pcs
	203.10.004	Contact Tip M8, Copper Chromium Zirconium CuCrZr Ø 1.6 mm - Ergoplus 36 - 500	10 Pcs
3	203.04.005	Tip Holder - M6, 28.0 mm Short - Ergoplus 36	5 Pcs / 10 Pcs
3.1	203.04.006	Tip Holder - M8, 28.0 mm Short - Ergoplus 36	5 Pcs / 10 Pcs
4	203.04.004	Gas Diffusor White Ceramic - L 32.8 mm - Ergoplus 36	5 Pcs / 10 Pcs
5	203.04.008	Torch head - Ergoplus 36	1 Pc

Pos	Item Code	Item Name	MoQ
6	203.13.002	Blue Insulated - Steel Liner - Wire Ø 0.6 - 0.9 mm at 4 m	1 Pc
	203.13.003	Blue Insulated - Steel Liner - Wire Ø 0.6 - 0.9 mm at 5 m	1 Pc
7	203.13.004	Red Insulated - Steel Liner - Wire Ø 1.0 - 1.2 mm at 3 m	1 Pc
	203.13.005	Red Insulated - Steel Liner - Wire Ø 1.0 - 1.2 mm at 4 m	1 Pc
	203.13.006	Red Insulated - Steel Liner - Wire Ø 1.0 - 1.2 mm at 5 m	1 Pc
8	203.14.003	Blue Teflon Liner - for Aluminum Wire Ø 0.6 - 0.9 mm at 5 m	1 Pc
9	203.14.004	Red Teflon Liner - for Aluminum Wire Ø 1.0 - 1.2 mm at 3 m	1 Pc
	203.14.005	Red Teflon Liner - for Aluminum Wire Ø 1.0 - 1.2 mm at 4 m	1 Pc
	203.14.006	Red Teflon Liner - for Aluminum Wire Ø 1.0 - 1.2 mm at 5 m	1 Pc
10	203.14.008	Yellow Teflon Liner - for Aluminum Wire Ø 1.2 - 1.6 mm at 4 m	1 Pc
11	203.14.010	Copper Liner - for Aluminum Wire up to 1.6 mm	1 Pc

Item Code	Item Name	MoQ
203.04.001	Mig Torch - Ergoplus 36 at 3 m long	1 Set
203.04.002	Mig Torch - Ergoplus 36 at 4 m long	1 Set
203.04.003	Mig Torch - Ergoplus 36 at 5 m long	1 Set
	<ul style="list-style-type: none"> • Contact Tip M8, E-Cu Ø 1.2 mm - Ergoplus 36 - 500 • Spanner mig accessory attached 	



Recommended Anti Spatter for better Welding result



MIG Gun - Water Cooled - Ergoplus 500



Advantageous

- Interchangeable with the best-known European brands
- A sturdy torch that combines the qualities of compactness and light weight with great reliability
- Ergonomic handle
- Torch with ball joint to ease welding movement
- Attachments : Euro with mobile pins

Specifications

Rating	500 A for CO2
	450 A for Mixed Gases M 21
	100 % Duty Cycle
Wire sizes	1.0 - 2.4 mm
Coolant Pressure	2 - 4 bar
Coolant Flow	1.6 l/min

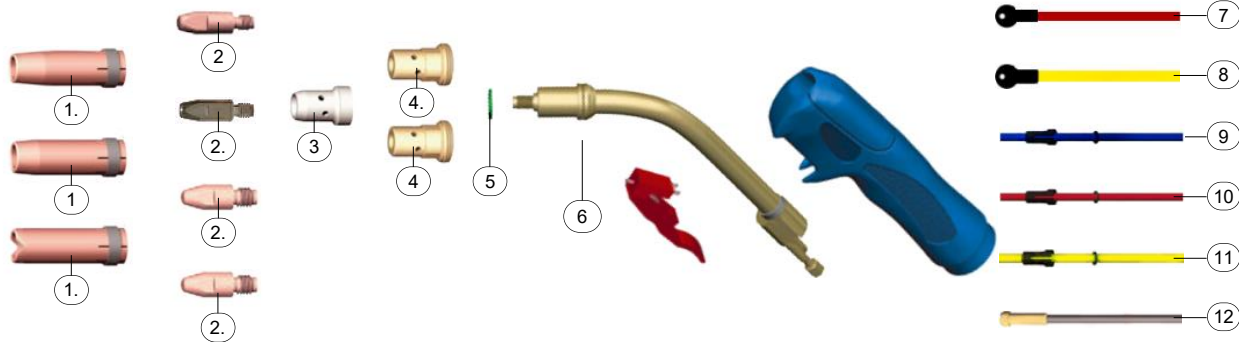

Pos	Item Code	Item Name	MoQ
1	203.05.007	Gas Nozzle - Conical Ø 16.0 mm - Ergoplus / Autoplus 500	2 Pcs / 10 Pcs
1.1	203.05.012	Gas Nozzle - Tapered Ø 15.0 mm - Ergoplus / Autoplus 500	2 Pcs / 10 Pcs
	203.05.011	Gas Nozzle - Tapered Ø 14.0 mm - Ergoplus / Autoplus 500	2 Pcs / 10 Pcs
1.2	203.05.013	Gas Nozzle - Spot Weld Ø 20.0 mm - Ergoplus / Autoplus 500	2 Pcs / 10 Pcs
2	203.08.001	Contact Tip M6, Pure Copper E-Cu Ø 0.8 mm - Ergoplus 24 - 36 - 500	10 Pcs
	203.08.002	Contact Tip M6, Pure Copper E-Cu Ø 0.9 mm - Ergoplus 24 - 36 - 500	10 Pcs
	203.08.003	Contact Tip M6, Pure Copper E-Cu Ø 1.0 mm - Ergoplus 24 - 36 - 500	10 Pcs
	203.08.004	Contact Tip M6, Pure Copper E-Cu Ø 1.2 mm - Ergoplus 24 - 36 - 500	10 Pcs
	203.08.005	Contact Tip M6, Pure Copper E-Cu Ø 1.6 mm - Ergoplus 24 - 36 - 500	10 Pcs
2.1	204.20.002	Contact Tip M6, Silver Plated - Ø 0.9 mm - Ergoplus 24 - 36 - 500	10 Pcs
	204.20.003	Contact Tip M6, Silver Plated - Ø 1.0 mm - Ergoplus 24 - 36 - 500	10 Pcs
	204.20.004	Contact Tip M6, Silver Plated - Ø 1.2 mm - Ergoplus 24 - 36 - 500	10 Pcs
2.2	203.09.001	Contact Tip M8, Pure Copper E-Cu Ø 1.0 mm - Ergoplus 36 - 500	10 Pcs
	203.09.002	Contact Tip M8, Pure Copper E-Cu Ø 1.2 mm - Ergoplus 36 - 500	10 Pcs
	203.09.003	Contact Tip M8, Pure Copper E-Cu Ø 1.4 mm - Ergoplus 36 - 500	10 Pcs
	203.09.004	Contact Tip M8, Pure Copper E-Cu Ø 1.6 mm - Ergoplus 36 - 500	10 Pcs
	203.09.005	Contact Tip M8, Pure Copper E-Cu Ø 2.0 mm - Ergoplus 36 - 500	10 Pcs
	203.09.006	Contact Tip M8, Pure Copper E-Cu Ø 2.4 mm - Ergoplus 36 - 500	10 Pcs
2.3	203.10.001	Contact Tip M8, Copper Chromium Zirconium CuCrZr Ø 1.0 mm - Ergoplus 36 - 500	10 Pcs
	203.10.002	Contact Tip M8, Copper Chromium Zirconium CuCrZr Ø 1.2 mm - Ergoplus 36 - 500	10 Pcs
	203.10.003	Contact Tip M8, Copper Chromium Zirconium CuCrZr Ø 1.4 mm - Ergoplus 36 - 500	10 Pcs
	203.10.004	Contact Tip M8, Copper Chromium Zirconium CuCrZr Ø 1.6 mm - Ergoplus 36 - 500	10 Pcs
3	203.05.004	Gas Diffusor White - Ergoplus / Autoplus 500	5 Pcs / 10 Pcs
4	203.05.005	Tip Holder - M6 Short - Ergoplus / Autoplus 500	2 Pcs / 10 Pcs
4.1	203.05.006	Tip Holder - M8 Short - Ergoplus / Autoplus 500	2 Pcs / 10 Pcs

Pos	Item Code	Item Name	MoQ
5	203.05.010	Insulator - Ergoplus / Autoplus 500	10 Std
6	203.05.008	Torch head - Ergoplus 500 - Ergoplus / Autoplus 500	1 Pc
7	203.13.007	Red Insulated Liner - Steel - Wire Ø 1.0 - 1.2 mm at 3 m	1 Pc
	203.13.008	Red Insulated Liner - Steel - Wire Ø 1.0 - 1.2 mm at 4 m	1 Pc
	203.13.009	Red Insulated Liner - Steel - Wire Ø 1.0 - 1.2 mm at 5 m	1 Pc
8	203.13.010	Insulated Liner Steel Yellow - Wire Ø 1.2 - 1.6 mm at 4 m	1 Pc
9	203.14.003	Blue Teflon Liner - For Aluminum Wire Ø 0.6 - 0.9 mm at 5 m	1 Pc
10	203.14.004	Red Teflon Liner - For Aluminum Wire Ø 1.0 - 1.2 mm at 3 m	1 Pc
	203.14.005	Red Teflon Liner - For Aluminum Wire Ø 1.0 - 1.2 mm at 4 m	1 Pc
	203.14.006	Red Teflon Liner - For Aluminum Wire Ø 1.0 - 1.2 mm at 5 m	1 Pc
11	203.14.008	Yellow Teflon Liner For Aluminum Wire Ø 1.2 - 1.6 mm at 4 m	1 Pc
12	203.14.010	Copper Liner - For Aluminum Wire up to 1.6 mm	1 Pc

Item Code	Item Name	MoQ
203.05.001	Mig Torch - Ergoplus 500 at 3 m long	1 Set
203.05.002	Mig Torch - Ergoplus 500 at 4 m long <ul style="list-style-type: none"> • Contact Tip M8, E-Cu Ø 1.2 mm - Ergoplus 36 - 500 • Spanner mig accessory attached 	1 Set



Recommended Anti Spatter for better Welding result



Better welding performances with Trafimet torch coolant



MIG Gun - Water Cooled - Autoplus 500



Advantageous

- Interchangeable with the best-known European brands
- A sturdy torch that combines the qualities of compactness and light weight with great reliability
- Ergonomic handle
- Articulation to ease cable bending
- Attachments : Euro with mobile pins

Specifications

Rating	500 A for CO2
	450 A for Mixed Gases M 21
	100 % Duty Cycle
Wire sizes	1.0 - 2.4 mm
Coolant Pressure	2 - 4 bar
Coolant Flow	1.6 l/min

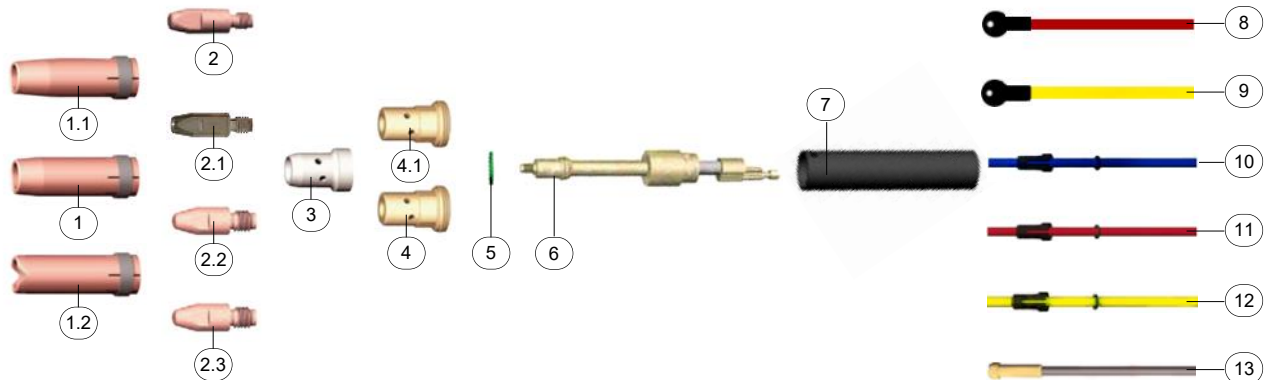

Pos	Item Code	Item Name	MoQ
1	203.05.007	Gas Nozzle - Conical Ø 16.0 mm - Ergoplus / Autoplus 500	2 Pcs / 10 Pcs
1.1	203.05.012	Gas Nozzle - Tapered Ø 15.0 mm - Ergoplus / Autoplus 500	2 Pcs / 10 Pcs
1.2	203.05.013	Gas Nozzle - Spot Weld Ø 20.0 mm - Ergoplus / Autoplus 500	2 Pcs / 10 Pcs
2	203.08.001	Contact Tip M6, Pure Copper E-Cu Ø 0.8 mm - Ergoplus 24 - 36 - 500	10 Pcs
	203.08.002	Contact Tip M6, Pure Copper E-Cu Ø 0.9 mm - Ergoplus 24 - 36 - 500	10 Pcs
	203.08.003	Contact Tip M6, Pure Copper E-Cu Ø 1.0 mm - Ergoplus 24 - 36 - 500	10 Pcs
	203.08.004	Contact Tip M6, Pure Copper E-Cu Ø 1.2 mm - Ergoplus 24 - 36 - 500	10 Pcs
	203.08.005	Contact Tip M6, Pure Copper E-Cu Ø 1.6 mm - Ergoplus 24 - 36 - 500	10 Pcs
2.1	204.20.002	Contact Tip M6, Silver Plated - Ø 0.9 mm - Ergoplus 24 - 36 - 500	10 Pcs
	204.20.003	Contact Tip M6, Silver Plated - Ø 1.0 mm - Ergoplus 24 - 36 - 500	10 Pcs
	204.20.004	Contact Tip M6, Silver Plated - Ø 1.2 mm - Ergoplus 24 - 36 - 500	10 Pcs
2.2	203.09.001	Contact Tip M8, Pure Copper E-Cu Ø 1.0 mm - Ergoplus 36 - 500	10 Pcs
	203.09.002	Contact Tip M8, Pure Copper E-Cu, Ø 1.2 mm - Ergoplus 36 - 500	10 Pcs
	203.09.003	Contact Tip M8, Pure Copper E-Cu, Ø 1.4 mm - Ergoplus 36 - 500	10 Pcs
	203.09.004	Contact Tip M8, Pure Copper E-Cu, Ø 1.6 mm - Ergoplus 36 - 500	10 Pcs
	203.09.005	Contact Tip M8, Pure Copper E-Cu, Ø 2.0 mm - Ergoplus 36 - 500	10 Pcs
	203.09.006	Contact Tip M8, Pure Copper E-Cu, Ø 2.4 mm - Ergoplus 36 - 500	10 Pcs
2.3	203.10.001	Contact Tip M8, Copper Chromium Zirconium CuCrZr Ø 1.0 mm - Ergoplus 36 - 500	10 Pcs
	203.10.002	Contact Tip M8, Copper Chromium Zirconium CuCrZr Ø 1.2 mm - Ergoplus 36 - 500	10 Pcs
	203.10.003	Contact Tip M8, Copper Chromium Zirconium CuCrZr Ø 1.4 mm - Ergoplus 36 - 500	10 Pcs
	203.10.004	Contact Tip M8, Copper Chromium Zirconium CuCrZr Ø 1.6 mm - Ergoplus 36 - 500	10 Pcs
3	203.05.004	Gas Diffusor White - Ergoplus / Autoplus 500	5 Pcs / 10 Pcs
4	203.05.005	Tip Holder - M6 Short - Ergoplus / Autoplus 500	5 Pcs / 10 Pcs
4.1	203.05.006	Tip Holder - M8 Short - Ergoplus / Autoplus 500	5 Pcs / 10 Pcs

Pos	Item Code	Item Name	MoQ
5	203.05.010	Insulator - Ergoplus / Autoplus 500	10 Pcs
6	203.05.008	Torch head - Ergoplus 500 - Ergoplus / Autoplus 500	1 Pc
7	503.01.006	Handle - Autoplus	1 Pc
8	203.13.007	Red Insulated Liner - Steel - Wire Ø 1.0 - 1.2 mm at 3 m	1 Pc
	203.13.008	Red Insulated Liner - Steel - Wire Ø 1.0 - 1.2 mm at 4 m	1 Pc
	203.13.009	Red Insulated Liner - Steel - Wire Ø 1.0 - 1.2 mm at 5 m	1 Pc
9	203.13.010	Insulated Liner Steel Yellow - Wire Ø 1.2 - 1.6 mm at 4 m	1 Pc
10	203.14.003	Blue Teflon Liner - For Aluminum Wire Ø 0.6 - 0.9 mm at 5 m	1 Pc
11	203.14.004	Red Teflon Liner - For Aluminum Wire Ø 1.0 - 1.2 mm at 3 m	1 Pc
	203.14.005	Red Teflon Liner - For Aluminum Wire Ø 1.0 - 1.2 mm at 4 m	1 Pc
	203.14.006	Red Teflon Liner - For Aluminum Wire Ø 1.0 - 1.2 mm at 5 m	1 Pc
12	203.14.008	Yellow Teflon Liner For Aluminum Wire Ø 1.2 - 1.6 mm at 4 m	1 Pc
13	203.14.010	Copper Liner - For Aluminum Wire up to 1.6 mm	1 Pc
-	203.12.006	Blue Teflon Liner 5m + Copper Liner - Aluminum Ø 0.8 - 0.9 mm	1 Set
-	203.12.007	Red Teflon Liner 5m + Copper Liner - Aluminum Ø 1.0 - 1.2 mm	1 Set
-	203.12.008	Yellow Teflon Liner 5m + Copper Liner - Aluminum Ø 1.2 - 1.6 mm	1 Set

Item Code	Item Name	MoQ
203.05.003	Autoplus 500 at 1.6 m	1 Set



Recommended Anti Spatter for better Welding result



Better welding performances with Trafimet torch coolant



MIG Torch - Air Cooled - Abimig 350 S



Advantageous

- Recognized worldwide for robust high quality torch
- Ergonomic and technically matured and 100% reliable
- Light and highly flexible cable assembly
- Optimum cooling of the torch, extending torch life
- Time-saving torch change over due to the Abicor Binzel central adaptor

Specifications

Rating	350 A for CO2
	320 A for Mixed Gases M 21
	60 % Duty Cycle
Wire sizes	1.0 - 1.6 mm



Pos.	Item Code	Item Name	MoQ
1	204.29.001	Gas Nozzle Plated Ø 18.0	2 Pcs
2	204.24.001	Contact Tip M8, Silver Plated - Ø 1.2 mm - Ergoplus 24 - 36 - 500	10 Pcs
	204.24.002	Contact Tip M8, Silver Plated - Ø 1.6 mm - Ergoplus 24 - 36 - 500	10 Pcs
	204.24.003	Contact Tip M8, Silver Plated - Ø 2.4 mm - Ergoplus 24 - 36 - 500	10 Pcs

Item Code	Item Name	MoQ
204.07.001	Mig Gun Abimig 350 S at 3 m 50° bent	1 Set



MIG Torch - Air Cooled - Abimig 450 V



Advantageous

- Recognized worldwide for robust high quality torch
- Ergonomic and technically matured and 100% reliable
- Light and highly flexible cable assembly
- Optimum cooling of the torch, extending torch life
- Time-saving torch change over due to the Abicor Binzel central adaptor

Specifications

Rating	450 A for CO2
	400 A for Mixed Gases M 21
	60 % Duty Cycle
Wire sizes	1.0 - 2.4 mm

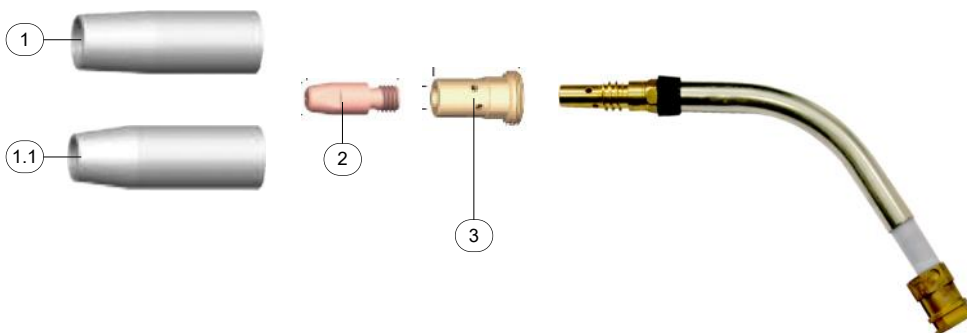

Pos.	Item Code	Item Name	MoQ
1	204.30.002	Gas Nozzle Tr 18, Plated Ø 19.0	1 Pc
1.1	204.30.003	Gas Nozzle Tr 18, Plated Ø 16.0	1 Pc
2	204.25.001	Contact Tip M10, Copper Chromium Zirconium CuCrZr - Ø 1.0 mm - Euro Style	10 Pcs
	204.25.002	Contact Tip M10, Copper Chromium Zirconium CuCrZr - Ø 1.2 mm - Euro Style	10 Pcs
	204.25.003	Contact Tip M10, Copper Chromium Zirconium CuCrZr - Ø 1.4 mm - Euro Style	10 Pcs
	204.25.004	Contact Tip M10, Copper Chromium Zirconium CuCrZr - Ø 1.6 mm - Euro Style	10 Pcs
	204.25.005	Contact Tip M10, Copper Chromium Zirconium CuCrZr - Ø 2.0 mm - Euro Style	10 Pcs
	204.25.006	Contact Tip M10, Copper Chromium Zirconium CuCrZr - Ø 2.4 mm - Euro Style	10 Pcs
3	204.30.001	Contact Tip holder Tr 18/M10/LH	2 Pcs

Item Code	Item Name	MoQ
204.07.003	Mig Gun Abimig 450 V at 4 m 50° bent	1 Set



MIG Torch - Air Cooled - Industrial



Advantageous

- Recognized worldwide for robust high quality torch
- Ergonomic and technically matured and 100% reliable
- Light and highly flexible cable assembly
- Optimum cooling of the torch, extending torch life
- Time-saving torch change over due to the Abicor Binzel central adaptor

Specifications

Rating	500 A for CO2
	400 A without Gas
	60 % Duty Cycle
Wire sizes	1.6 - 3.2 mm

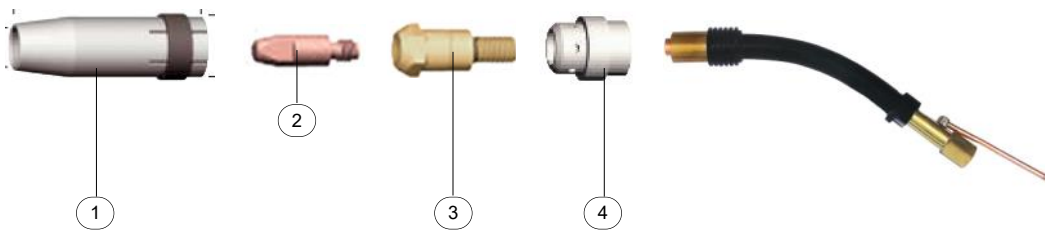

Pos.	Item Code	Item Name	MoQ
1	204.31.001	Cas Nozzle Conical, ND Ø 20.0	1 Pc
2	204.25.004	Contact Tip M10, Copper Chromium Zirconium CuCrZr - Ø 1.6 mm - Euro Style	10 Pcs
	204.25.005	Contact Tip M10, Copper Chromium Zirconium CuCrZr - Ø 2.0 mm - Euro Style	10 Pcs
	204.25.006	Contact Tip M10, Copper Chromium Zirconium CuCrZr - Ø 2.4 mm - Euro Style	10 Pcs
	204.25.007	Contact Tip M10, Copper Chromium Zirconium CuCrZr - Ø 2.8 mm - Euro Style	10 Pcs
3	204.31.003	Contact Tip Holder M10, 40.0 mm - RB 61 GD	2 Pcs
4	204.31.002	Gas Diffusor White	1 Pc
	204.31.004	Guide spiral liner for bent swan neck = 223 mm	1 Pc

Item Code	Item Name	MoQ
204.10.001	RB 61 GD at 4 m 35° bent	1 Set
204.10.002	Auto RB 61 GD at 1.3 m 22°	1 Set
204.10.003	Auto RB 61 GD at 4 m	1 Set



Alpha Flux 350 S - KZ -2, 65° bent



Advantageous

- Flux-Cored Self Shielding Welding Torch
- Ceramic insulation - extreme high temperature durability
- Robust heat protection shield for optimal heat deflection
- Quick - change torch neck, fixable at all angles
- Silver-plated contact tips - low spatter adhesion
- Highly flexible coaxial cable BIKOX® R

Specifications

Rating	330 A with self shielding Flux-Cored Wire
	60 % Duty Cycle
Wire sizes	1.2 - 2.4 mm

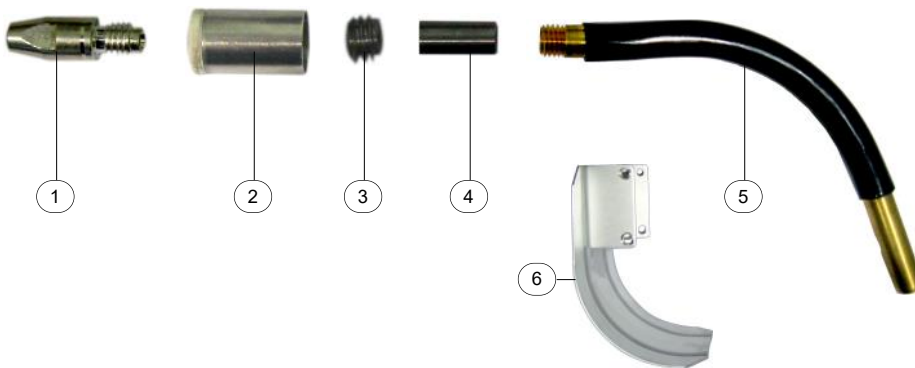

Pos	Item Code	Item Name	MoQ
1	204.24.001	Contact Tip M8, Silver Plated - Ø 1.2 mm - Ergoplus 24 - 36 - 500	10 Pcs
	204.24.002	Contact Tip M8, Silver Plated - Ø 1.6 mm - Ergoplus 24 - 36 - 500	10 Pcs
	204.24.003	Contact Tip M8, Silver Plated - Ø 2.4 mm - Ergoplus 24 - 36 - 500	10 Pcs
2	-	Insulator 1 ALPHA FLUX	1 Pc
3	-	102 - Threaded Pin M8 / 4.0 mm	1 Pc
4	-	103 - Sleeve Ø 3.5 mm, L = 12 mm, for wire up to Ø 2.0 mm	1 Pc
5	-	Swan neck Alpha Flux 350 M8 , 65° , X = 108 , Y = 115 , wire up to Ø 2.0 mm	1 Pc
6	-	Hand Shield for Alpha Flux	1 Pc

Item Code	Item Name	MoQ
204.08.001	Alpha Flux 350 S at 3 m - KZ-2, 65° bent	1 Set



MIG Gun - Liquid Cooled - MB 602



Advantageous

- Recognized worldwide for robust high quality torch
- Ergonomic and technically matured and 100% reliable
- Light and highly flexible cable assembly
- Optimum cooling of the torch, extending torch life
- Silver-plated contact tips - low spatter adhesion
- Time-saving torch change over due to the Abicor Binzel central adaptor

Specifications

Rating	600 A for CO2
	550 A for Mixed Gases M 21
	100 % Duty Cycle
Wire sizes	1.0 - 1.6 mm (2.4 mm)

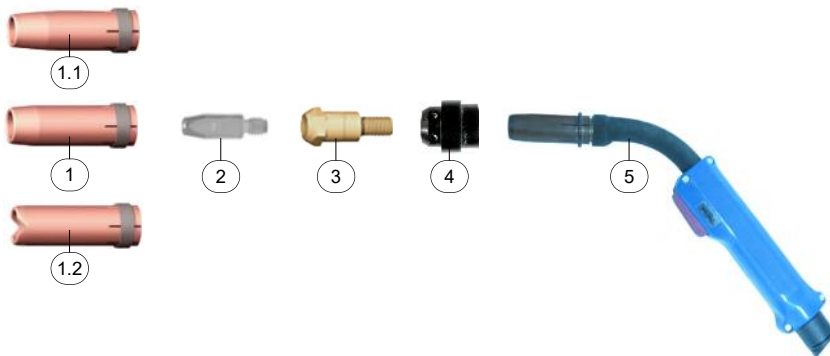

Pos.	Item Code	Item Name	MoQ
1	204.34.004	Gas Nozzle Conical Ø 18.0	2 Pcs
1.1	204.34.005	Gas Nozzle Tapered Ø 15.5	2 Pcs
1.2	204.34.006	Gas Nozzle Spot weld Ø 21.0	1 Pc
2	204.24.001	Contact Tip M8, Silver Plated - Ø 1.2 mm - Ergo plus 24 - 36 - 500	10 Pcs
	204.24.002	Contact Tip M8, Silver Plated - Ø 1.6 mm - Ergo plus 24 - 36 - 500	10 Pcs
3	204.34.003	Contact Tip Holder M8, 24.0 mm	4 Pcs
4	204.34.002	Gas Diffuser Black	2 Pcs
5	204.34.001	Outer Cover Black	1 Pc

Item Code	Item Name	MoQ
204.11.001	MB 602 at 4 m 50° bent	1 Set



Robo Torch ABIROB 350 GC 35° bent



Advantageous

- Quick neck change system, increase of system up time
- Better temperature behaviour, hence higher component life time, cost reduction and increase system up time
- EN-related construction by fully isolated electrical parts, safety rules for employees are fulfilled
- Better price/performance relation and global availability of spare parts due to BINZEL world wide distribution network, cost reduction and easy order system
- Further compatibility is given in the contact tip, with the advantage of BINZEL tip which is proved to give longer life compared to competitors product. This is due to higher material quality and machining accuracy, better welding result, increase up time and cost reduction
- A unique welding torch designed with compatible Tool Center Point geometry and clamping area
- Quick replacement swan neck and cable assembly without affecting the Tool Center Point

Specifications

Torch	ABIROB 350 GC
Cooling	Air
Duty Cycle	100 %
Rating	350 A
Wire-Ø	0.9 - 1.2 mm

- All data related to welding with CO₂ gas.
- Rating capacity 400 A at 60%.
- All ratings will be reduced by approx. 35 % when welding using pulse arc and using mixed gas.

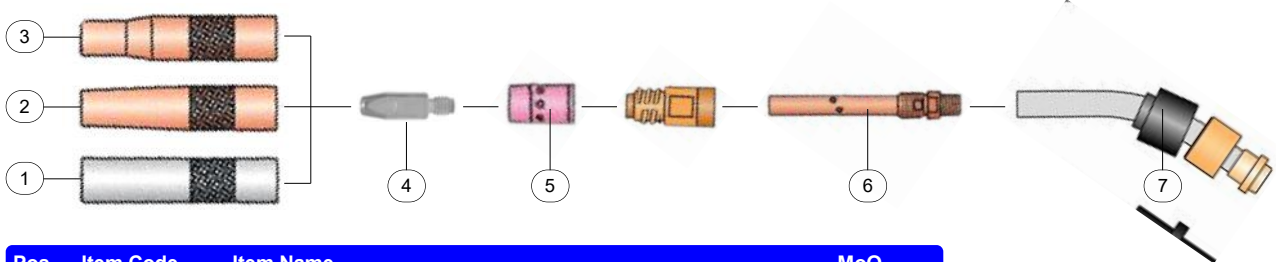

Pos.	Item Code	Item Name	MoQ
1	204.43.002	Gas Nozzle Conical Ø 15.6	5 Pcs
2	204.43.003	Gas Nozzle Tapered Ø 12.0	5 Pcs
3	204.43.008	Gas Nozzle Special Ø 14.0	5 Pcs
4	204.20.001	Contact Tip M6, Silver Plated - Ø 0.8 mm - Ergoplus 24 - 36 - 500	10 Pcs
	204.20.002	Contact Tip M6, Silver Plated - Ø 0.9 mm - Ergoplus 24 - 36 - 500	10 Pcs
	204.20.003	Contact Tip M6, Silver Plated - Ø 1.0 mm - Ergoplus 24 - 36 - 500	10 Pcs
	204.20.004	Contact Tip M6, Silver Plated - Ø 1.2 mm - Ergoplus 24 - 36 - 500	10 Pcs
5	204.43.007	Insulator	5 Pcs
6	204.43.001	Gas Diffussor Pink	10 Pcs
7	204.43.006	Isolation Cap	1 Pc

Item Code	Item Name	MoQ
204.41.004	350 GC 35° bent 1.1 m	1 Set



Central Adaptor



We offer a wide range of Central adaptors, for all range of Mig Mag or CO2 machines.

Central Adaptor for Non Euro Connector		
Item Code	Item Name	MoQ
208.20.007	Central Adaptor - Common Ones	1 Pc
208.20.008	Central Adaptor - OTC - Wire Feeder CM 302	1 Pc
208.20.009	Central Adaptor - OTC - Wire Feeder CM 2301	1 Pc
208.20.010	Central Adaptor - Panasonic - Wire Feeder YW 50 KBL 3	1 Pc
208.20.011	Central Adaptor - ESAB - Wire Feeder A10	1 Pc
208.20.012	Central Adaptor - Panasonic - OTC - Daiden - Common Small	1 Pc
208.20.013	Central Adaptor - Lincoln - Wire Feeder Eurotrac	1 Pc
208.20.014	Central Adaptor - Miller - Wire Feeder S-54 E	1 Pc
208.20.015	Central Adaptor - OTC - Wire Feeder CM 231	1 Pc
208.20.016	Central Adaptor - Hobart - Wire Feeder 2000, 2200, 2400, 2410, 2450	1 Pc
208.20.017	Central Adaptor - Fronius - 350/450 Compact / VR 123 / Veristor 263	1 Pc
208.20.018	Central Adaptor - Messer Greisheim - Wire Feeder MIGBOY 200	1 Pc
208.20.019	Central Adaptor - Panasonic - Common Big	1 Pc
208.20.020	Central Adaptor - SAF - Wire Feeder OPTIMAG 500	1 Pc
208.20.021	Central Adaptor - Miller - Wire Feeder S 22 A	1 Pc
208.20.022	Central Adaptor - Lincoln - Wire Feeder LN 25	1 Pc
CALL	Other Central Adaptors	1 Pc



Water Cooled Hose Package

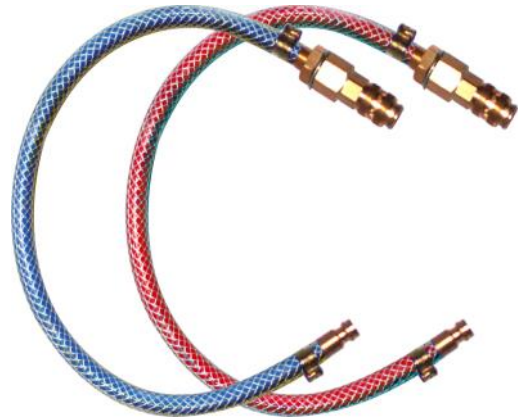

Advantageous

- DACH Hose Package is designed purposely for a connection between Water Re-circulator and any water cooled Tig torch or Mig Mag torch
- We use the best part for production, to maintain our quality brand
- We could assure for a proven durability, starting from light to heavy use of water cooled application

Item Code	Item Name	MoQ
208.11.001	Water Cooled Hose Package - Blue & Red at 1 m	1 Set
208.11.002	Water Cooled Hose Package - Blue & Red at 2 m	1 Set
208.11.003	Water Cooled Hose Package - Blue & Red at 3 m	1 Set
208.11.004	Water Cooled Hose Package - Blue & Red at 4 m	1 Set
208.11.005	Water Cooled Hose Package - Blue & Red at 5 m	1 Set
208.11.006	Water Cooled Hose Package - Blue & Red at 6 m	1 Set
208.11.007	Water Cooled Hose Package - Blue & Red at 7 m	1 Set
208.11.008	Water Cooled Hose Package - Blue & Red at 8 m	1 Set
208.11.009	Water Cooled Hose Package - Blue & Red at 9 m	1 Set
208.11.010	Water Cooled Hose Package - Blue & Red at 10 m	1 Set
208.11.011	Water Cooled Hose Package - Blue & Red at 11 m	1 Set
208.11.012	Water Cooled Hose Package - Blue & Red at 12 m	1 Set
208.11.013	Water Cooled Hose Package - Blue & Red at 13 m	1 Set
208.11.014	Water Cooled Hose Package - Blue & Red at 14 m	1 Set
208.11.015	Water Cooled Hose Package - Blue & Red at 15 m	1 Set
208.11.016	Water Cooled Hose Package - Blue & Red at 16 m	1 Set
208.11.017	Water Cooled Hose Package - Blue & Red at 17 m	1 Set
208.11.018	Water Cooled Hose Package - Blue & Red at 18 m	1 Set
208.11.019	Water Cooled Hose Package - Blue & Red at 19 m	1 Set
208.11.020	Water Cooled Hose Package - Blue & Red at 20 m	1 Set
208.11.021	Water Cooled Hose Package - Blue & Red at 21 m	1 Set



Coolant



Advantageous

- Works in range of temperatures between -20° C to +120° C
- Lubricates the rotating gears
- Low dielectric conductivity
- Anti corrosion
- Compatible with plastic materials
- Increase welding torch liquid cooled performances

Specifications

Type of active substance	Vegetable fatty acid components with water emulsifiable
Density (20°C)	0.900kg/l
Viscosity	na
Flash - point	> 30 °C
Initial Boiling Point	90 °C
Pour Point	-3° C
pH - value	7
VOC (Directive 1999/13/EC)	25,00 % - 225,00 g/l
VOC (volatile carbon)	13,02 % - 117,21 g/l

Item Code	Package Type	MoQ
203.42.001	10 l Cooling	1 Pc

Suitable Liquid Cooled Torches

GMAW / MIG Ergoplus 500 Autoplus 500



Binzel MB 602





TIG Torches - Air Cooled - WP 9 V - 25 - 2

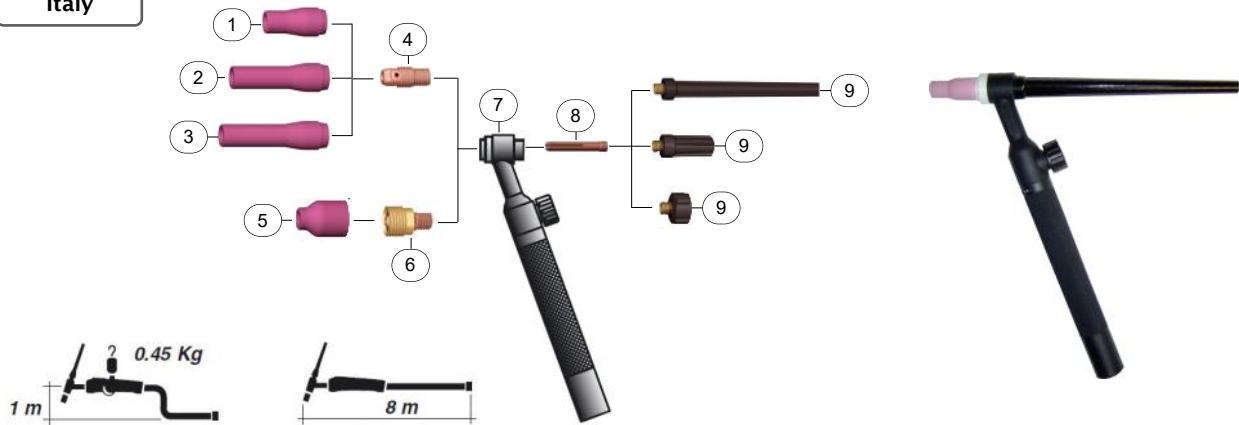

Advantageous

- The best known and used Tig torch in the world
- High quality and technology for trouble free performance whatever the welding jobs are
- Very flexible welding cable with high insulation level
- Wearing parts compatible with international standard
- Silicone Rubber torch bodies, reduce the possibility of accidental damage during use or the loss of high frequency signal due to torch body failure

Specifications

Type of Cooling	Air
Gas Flow	5 - 12 l/min
Duty Cycle 35 % DC	110 A
Duty Cycle 35 % AC	95 A
Tungsten Electrode Ø	2.4 mm

Pos	Item Code	Item Name	MoQ
1	203.25.001	Alumina Nozzle Short No. 4 (13N08) - TIG 9 - 20	10 Pcs
	203.25.002	Alumina Nozzle Short No. 5 (13N09) - TIG 9 - 20	10 Pcs
	203.25.003	Alumina Nozzle Short No. 6 (13N10) - TIG 9 - 20	10 Pcs
	203.25.004	Alumina Nozzle Short No. 7 (13N11) - TIG 9 - 20	10 Pcs
	203.25.005	Alumina Nozzle Short No. 8 (13N12) - TIG 9 - 20	10 Pcs
	203.25.006	Alumina Nozzle Short No.10 (13N13) - TIG 9 - 20	10 Pcs
2	203.26.001	Alumina Nozzle Long No. 4 (796F71) - TIG 9 - 20	10 Pcs
	203.26.002	Alumina Nozzle Long No. 5 (796F71) - TIG 9 - 20	10 Pcs
	203.26.003	Alumina Nozzle Long No. 6 (796F73) - TIG 9 - 20	10 Pcs
3	203.26.004	Alumina Nozzle Extra Long No. 4 (796F75) - TIG 9 - 20	10 Pcs
	203.26.005	Alumina Nozzle Extra Long No. 5 (796F76) - TIG 9 - 20	10 Pcs
4	203.29.001	Collet Body Ø 1.6 mm (13N27) - TIG 9 - 20	3 Pcs
	203.29.002	Collet Body Ø 2.4 mm (13N28) - TIG 9 - 20	3 Pcs
5	203.27.001	Alumina Nozzle Short Gas Lens No. 4 (53N58) - TIG 9 - 20	10 Pcs
	203.27.002	Alumina Nozzle Short Gas Lens No. 5 (53N59) - TIG 9 - 20	10 Pcs
	203.27.003	Alumina Nozzle Short Gas Lens No. 6 (53N60) - TIG 9 - 20	10 Pcs
	203.27.004	Alumina Nozzle Short Gas Lens No. 7 (53N61) - TIG 9 - 20	10 Pcs
6	203.30.001	Collet Body Gas Lens Ø 1.6 mm (45V43) - TIG 9 - 20	3 Pcs
	203.30.002	Collet Body Gas Lens Ø 2.4 mm (45V44) - TIG 9 - 20	3 Pcs
7	203.32.001	Torch Head WP 9 V	1 Pc
	203.32.002	Torch Head Flexible WP 9 FV	1 Pc
8	203.28.001	Collet Ø 1.6 mm (13N22) - TIG 9 - 20	5 Pcs
	203.28.002	Collet Ø 2.4 mm (13N23) - TIG 9 - 20	5 Pcs
9	203.31.001	Back Cap Long (41V24) - TIG 9 - 20	3 Pcs
	203.31.002	Back Cap Medium (41V35) - TIG 9 - 20	3 Pcs
	203.31.003	Back Cap Short (41V33) - TIG 9 - 20	3 Pcs

Recommended

- 1 Kobewel Solarmatic Helmet



- 2 DACH Tungsten Electrodes

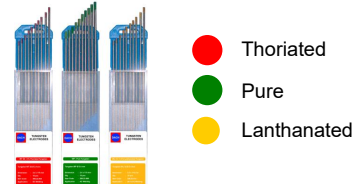

- 3 Inelco Tungsten Grinder



Item Code	Item Name	MoQ
203.16.001	TIG Torch - Air Cooled - WP 9 V-25-2 at 8 m	1 Set
203.16.002	TIG Torch - Air Cooled - WP 9 V-25-2 at 8 m - Flexible	1 Set



TIG Torches - Air Cooled - WP 17 V - 25 - 2

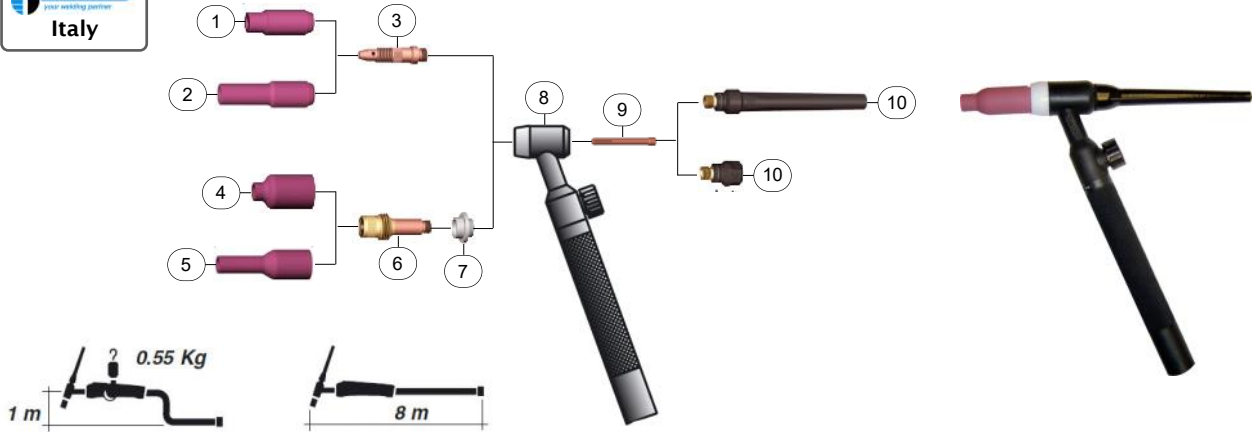

Advantageous

- The best known and used Tig torch in the world
- High quality and technology for trouble free performance whatever the welding jobs are
- Very flexible welding cable with high insulation level
- Wearing parts compatible with international standard
- Silicone Rubber torch bodies, reduce the possibility of accidental damage during use or the loss of high frequency signal due to torch body failure

Specifications

Type of Cooling	Air
Gas Flow	7 - 15 l/min
Duty Cycle 35 % DC	140 A
Duty Cycle 35 % AC	125 A
Tungsten Electrode Ø	1.6 - 2.4 mm

Pos	Item Code	Item Name	MoQ
1	203.17.001	Alumina Nozzle Short No. 5 (10N49) - TIG 17 - 26 - 18	10 Pcs
	203.17.002	Alumina Nozzle Short No. 6 (10N48) - TIG 17 - 26 - 18	10 Pcs
	203.17.003	Alumina Nozzle Short No. 7 (10N47) - TIG 17 - 26 - 18	10 Pcs
	203.17.004	Alumina Nozzle Short No. 8 (10N46) - TIG 17 - 26 - 18	10 Pcs
	203.17.005	Alumina Nozzle Short No. 10 (10N45) - TIG 17 - 26 - 18	10 Pcs
	203.17.006	Alumina Nozzle Short No. 12 (10N44) - TIG 17 - 26 - 18	10 Pcs
2	203.18.001	Alumina Nozzle Long No. 5 (10N49L) - TIG 17 - 26 - 18	10 Pcs
	203.18.002	Alumina Nozzle Long No. 6 (10N48L) - TIG 17 - 26 - 18	10 Pcs
	203.18.003	Alumina Nozzle Long No. 7 (10N47L) - TIG 17 - 26 - 18	10 Pcs
3	203.22.001	Collet Body Ø 1.6 mm (10N31) - TIG 17 - 26 - 18	3 Pcs
	203.22.002	Collet Body Ø 2.4 mm (10N32) - TIG 17 - 26 - 18	3 Pcs
4	203.19.001	Alumina Nozzle Short Gas Lens No. 4 (54N18) - TIG 17 - 26 - 18	10 Pcs
	203.19.002	Alumina Nozzle Short Gas Lens No. 5 (54N17) - TIG 17 - 26 - 18	10 Pcs
	203.19.003	Alumina Nozzle Short Gas Lens No. 6 (54N16) - TIG 17 - 26 - 18	10 Pcs
	203.19.004	Alumina Nozzle Short Gas Lens No. 7 (54N15) - TIG 17 - 26 - 18	10 Pcs
	203.19.005	Alumina Nozzle Short Gas Lens No. 8 (54N14) - TIG 17 - 26 - 18	10 Pcs
	203.19.006	Alumina Nozzle Short Gas Lens No. 12 (54N19) - TIG 17 - 26 - 18	10 Pcs
5	203.20.001	Alumina Nozzle Long Gas Lens No. 5 (54N17L) - TIG 17 - 26 - 18	10 Pcs
	203.20.002	Alumina Nozzle Long Gas Lens No. 6 (54N16L) - TIG 17 - 26 - 18	10 Pcs
	203.20.003	Alumina Nozzle Long Gas Lens No. 7 (54N15L) - TIG 17 - 26 - 18	10 Pcs
6	203.23.001	Collet Body Gas Lens Ø 1.6 mm (45V25) - TIG 17 - 26 - 18	3 Pcs
	203.23.002	Collet Body Gas Lens Ø 2.4 mm (45V26) - TIG 17 - 26 - 18	3 Pcs
7	203.23.005	Collet Body Gas Lens Insulator (54N01) - TIG 17 - 26 - 18	3 Pcs
8	203.32.003	Torch Head WP 17V	1 Pc
	203.32.004	Torch Head Flexible WP 17 FV	1 Pc
9	203.21.001	Collet Ø 1.6 mm (10N23) - TIG 17 - 26 - 18	5 Pcs
	203.21.002	Collet Ø 2.4 mm (10N24) - TIG 17 - 26 - 18	5 Pcs
10	203.24.001	Back Cap Long (57Y02) - TIG 17 - 26 - 18	3 Pcs
	203.24.002	Back Cap Short (57Y04) - TIG 17 - 26 - 18	3 Pcs

Recommended

1 Kobewel Solarmatic Helmet



2 DACH Tungsten Electrodes

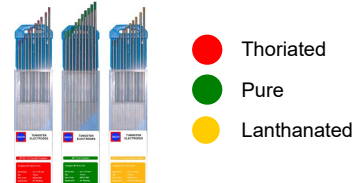

3 Inelco Tungsten Grinder



Item Code	Item Name	MoQ
203.16.003	TIG Torch - Air Cooled - WP 17 V-25-2 at 8 m	1 Set
203.16.004	TIG Torch - Air Cooled - WP 17 V-25-2 at 8 m Flexible	1 Set



TIG Torches - Air Cooled - WP 26 V - 25 - 2

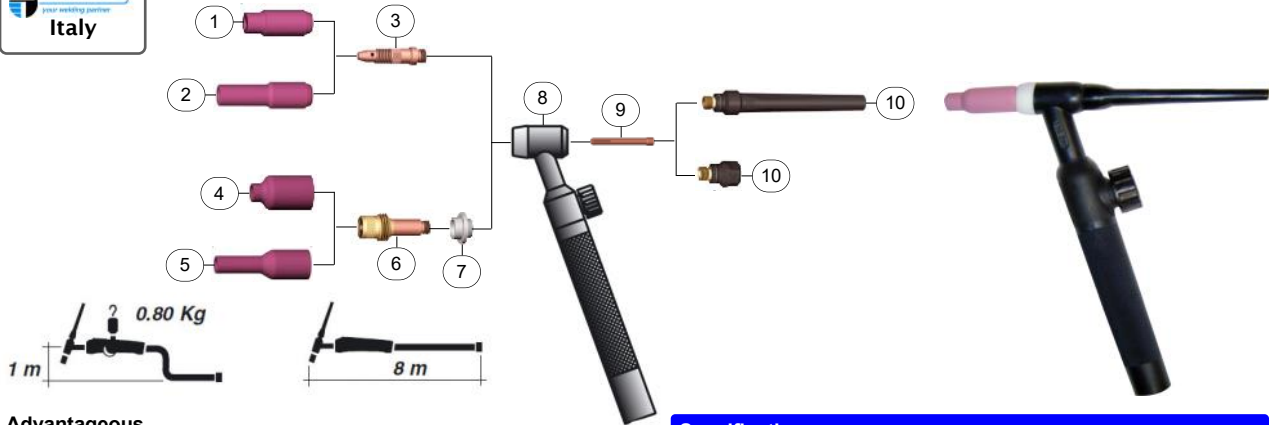

Advantageous

- The best known and used Tig torch in the world
- High quality and technology for trouble free performance whatever the welding jobs are
- Very flexible welding cable with high insulation level
- Wearing parts compatible with international standard
- Silicone Rubber torch bodies, reduce the possibility of accidental damage during use or the loss of high frequency signal due to torch body failure

Specifications

Type of Cooling	Air
Gas Flow	7 - 18 l/min
Duty Cycle 35 % DC	180 A
Duty Cycle 35 % AC	150 A
Tungsten Electrode Ø	1.6 - 4.0 mm

Pos	Item Code	Item Name	MoQ
1	203.17.001	Alumina Nozzle Short No. 5 (10N49) - TIG 17 - 26 - 18	10 Pcs
	203.17.002	Alumina Nozzle Short No. 6 (10N48) - TIG 17 - 26 - 18	10 Pcs
	203.17.003	Alumina Nozzle Short No. 7 (10N47) - TIG 17 - 26 - 18	10 Pcs
	203.17.004	Alumina Nozzle Short No. 8 (10N46) - TIG 17 - 26 - 18	10 Pcs
	203.17.005	Alumina Nozzle Short No. 10 (10N45) - TIG 17 - 26 - 18	10 Pcs
	203.17.006	Alumina Nozzle Short No. 12 (10N44) - TIG 17 - 26 - 18	10 Pcs
2	203.18.001	Alumina Nozzle Long No. 5 (10N49L) - TIG 17 - 26 - 18	10 Pcs
	203.18.002	Alumina Nozzle Long No. 6 (10N48L) - TIG 17 - 26 - 18	10 Pcs
	203.18.003	Alumina Nozzle Long No. 7 (10N47L) - TIG 17 - 26 - 18	10 Pcs
	203.18.004	Alumina Nozzle Long No. 8 (10N46L) - TIG 17 - 26 - 18	10 Pcs
3	203.22.001	Collet Body Ø 1.6 mm (10N31) - TIG 17 - 26 - 18	3 Pcs
	203.22.002	Collet Body Ø 2.4 mm (10N32) - TIG 17 - 26 - 18	3 Pcs
	203.22.003	Collet Body Ø 3.2 mm (10N28) - TIG 17 - 26 - 18	3 Pcs
	203.22.004	Collet Body Ø 4.0 mm (406488) - TIG 17 - 26 - 18	3 Pcs
4	203.19.001	Alumina Nozzle Short Gas Lens No. 4 (54N18) - TIG 17 - 26 - 18	10 Pcs
	203.19.002	Alumina Nozzle Short Gas Lens No. 5 (54N17) - TIG 17 - 26 - 18	10 Pcs
	203.19.003	Alumina Nozzle Short Gas Lens No. 6 (54N16) - TIG 17 - 26 - 18	10 Pcs
	203.19.004	Alumina Nozzle Short Gas Lens No. 7 (54N15) - TIG 17 - 26 - 18	10 Pcs
	203.19.005	Alumina Nozzle Short Gas Lens No. 8 (54N14) - TIG 17 - 26 - 18	10 Pcs
	203.19.006	Alumina Nozzle Short Gas Lens No. 12 (54N19) - TIG 17 - 26 - 18	10 Pcs
5	203.20.001	Alumina Nozzle Long Gas Lens No. 5 (54N17L) - TIG 17 - 26 - 18	10 Pcs
	203.20.002	Alumina Nozzle Long Gas Lens No. 6 (54N16L) - TIG 17 - 26 - 18	10 Pcs
	203.20.003	Alumina Nozzle Long Gas Lens No. 7 (54N15L) - TIG 17 - 26 - 18	10 Pcs
6	203.23.001	Collet Body Gas Lens Ø 1.6 mm (45V25) - TIG 17 - 26 - 18	3 Pcs
	203.23.002	Collet Body Gas Lens Ø 2.4 mm (45V26) - TIG 17 - 26 - 18	3 Pcs
	203.23.003	Collet Body Gas Lens Ø 3.2 mm (45V27) - TIG 17 - 26 - 18	3 Pcs
	203.23.004	Collet Body Gas Lens Ø 4.0 mm (45V28) - TIG 17 - 26 - 18	3 Pcs
7	203.23.005	Collet Body Gas Lens Insulator (54N01) - TIG 17 - 26 - 18	3 Pcs
8	203.32.005	Torch Head WP 26 V	1 Pc
	203.32.006	Torch Head Flexible WP 26 FV	1 Pc
9	203.21.001	Collet Ø 1.6 mm (10N23) - TIG 17 - 26 - 18	5 Pcs
	203.21.002	Collet Ø 2.4 mm (10N24) - TIG 17 - 26 - 18	5 Pcs
	203.21.003	Collet Ø 3.2 mm (10N25) - TIG 17 - 26 - 18	5 Pcs
	203.21.004	Collet Ø 4.0 mm (54N20) - TIG 17 - 26 - 18	5 Pcs
10	203.24.001	Back Cap Long (57Y02) - TIG 17 - 26 - 18	3 Pcs
	203.24.002	Back Cap Short (57Y04) - TIG 17 - 26 - 18	3 Pcs

Item Code	Item Name	MoQ
203.16.005	TIG Torch - Air Cooled - WP 26 V-25-2 at 8 m	1 Set
203.16.006	TIG Torch - Air Cooled - WP 26 V-25-2 at 8 m - Flexible	1 Set

Recommended

- 1 Kobewel Solarmatic Helmet



- 2 DACH Tungsten Electrodes

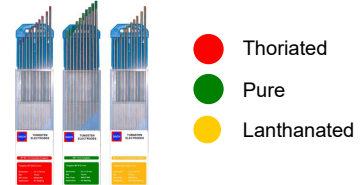

- 3 Inelco Tungsten Grinder





TIG Torches - Air Cooled - Auto TIG 26

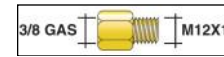
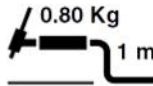
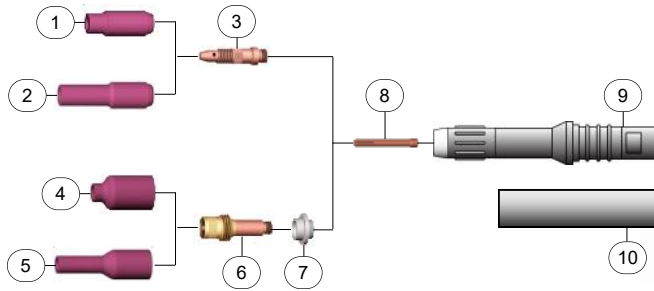

Advantageous

- The best known and used Tig torch in the world
- High quality and technology for trouble free performance whatever the welding jobs are
- Very flexible welding cable with high insulation level
- Wearing parts compatible with international standard
- Silicone Rubber torch bodies, reduce the possibility of accidental damage during use or the loss of high frequency signal due to torch body failure

Specifications

Type of Cooling	Air
Duty Cycle 35 % DC	180 A
Duty Cycle 35 % AC	150 A
Tungsten Electrode Ø	1.6 - 4.0 mm

Pos	Item Code	Item Name	MoQ
1	203.17.001	Alumina Nozzle Short No. 5 (10N49) - TIG 17 - 26 - 18	10 Pcs
	203.17.002	Alumina Nozzle Short No. 6 (10N48) - TIG 17 - 26 - 18	10 Pcs
	203.17.003	Alumina Nozzle Short No. 7 (10N47) - TIG 17 - 26 - 18	10 Pcs
	203.17.004	Alumina Nozzle Short No. 8 (10N46) - TIG 17 - 26 - 18	10 Pcs
	203.17.005	Alumina Nozzle Short No. 10 (10N45) - TIG 17 - 26 - 18	10 Pcs
	203.17.006	Alumina Nozzle Short No. 12 (10N44) - TIG 17 - 26 - 18	10 Pcs
2	203.18.001	Alumina Nozzle Long No. 5 (10N49L) - TIG 17 - 26 - 18	10 Pcs
	203.18.002	Alumina Nozzle Long No. 6 (10N48L) - TIG 17 - 26 - 18	10 Pcs
	203.18.003	Alumina Nozzle Long No. 7 (10N47L) - TIG 17 - 26 - 18	10 Pcs
3	203.22.001	Collet Body Ø 1.6 mm (10N31) - TIG 17 - 26 - 18	3 Pcs
	203.22.002	Collet Body Ø 2.4 mm (10N32) - TIG 17 - 26 - 18	3 Pcs
	203.22.003	Collet Body Ø 3.2 mm (10N28) - TIG 17 - 26 - 18	3 Pcs
	203.22.004	Collet Body Ø 4.0 mm (406488) - TIG 17 - 26 - 18	3 Pcs
4	203.19.001	Alumina Nozzle Short Gas Lens No. 4 (54N18) - TIG 17 - 26 - 18	10 Pcs
	203.19.002	Alumina Nozzle Short Gas Lens No. 5 (54N17) - TIG 17 - 26 - 18	10 Pcs
	203.19.003	Alumina Nozzle Short Gas Lens No. 6 (54N16) - TIG 17 - 26 - 18	10 Pcs
	203.19.004	Alumina Nozzle Short Gas Lens No. 7 (54N15) - TIG 17 - 26 - 18	10 Pcs
	203.19.005	Alumina Nozzle Short Gas Lens No. 8 (54N14) - TIG 17 - 26 - 18	10 Pcs
	203.19.006	Alumina Nozzle Short Gas Lens No. 12 (54N19) - TIG 17 - 26 - 18	10 Pcs
5	203.20.001	Alumina Nozzle Long Gas Lens No. 5 (54N17L) - TIG 17 - 26 - 18	10 Pcs
	203.20.002	Alumina Nozzle Long Gas Lens No. 6 (54N16L) - TIG 17 - 26 - 18	10 Pcs
	203.20.003	Alumina Nozzle Long Gas Lens No. 7 (54N15L) - TIG 17 - 26 - 18	10 Pcs
6	203.23.001	Collet Body Gas Lens Ø 1.6 mm (45V25) - TIG 17 - 26 - 18	3 Pcs
	203.23.002	Collet Body Gas Lens Ø 2.4 mm (45V26) - TIG 17 - 26 - 18	3 Pcs
	203.23.003	Collet Body Gas Lens Ø 3.2 mm (45V27) - TIG 17 - 26 - 18	3 Pcs
	203.23.004	Collet Body Gas Lens Ø 4.0 mm (45V28) - TIG 17 - 26 - 18	3 Pcs
7	203.23.005	Collet Body Gas Lens Insulator (54N01) - TIG 17 - 26 - 18	3 Pcs
8	203.21.001	Collet Ø 1.6 mm (10N23) - TIG 17 - 26 - 18	5 Pcs
	203.21.002	Collet Ø 2.4 mm (10N24) - TIG 17 - 26 - 18	5 Pcs
	203.21.003	Collet Ø 3.2 mm (10N25) - TIG 17 - 26 - 18	5 Pcs
	203.21.004	Collet Ø 4.0 mm (54N20) - TIG 17 - 26 - 18	5 Pcs
9	203.32.015	Auto Tig 26 Torch Head	1 Pc
10	503.01.033	Black Handle	1 Pc

Recommended

1 Kobewel Solarmatic Helmet



2 DACH Tungsten Electrodes

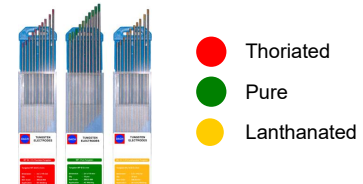

3 Inelco Tungsten Grinder



Item Code	Item Name	MoQ
203.16.020	Tig Torch - Air Cooled - Auto TIG 26 at 4 m	1 Set

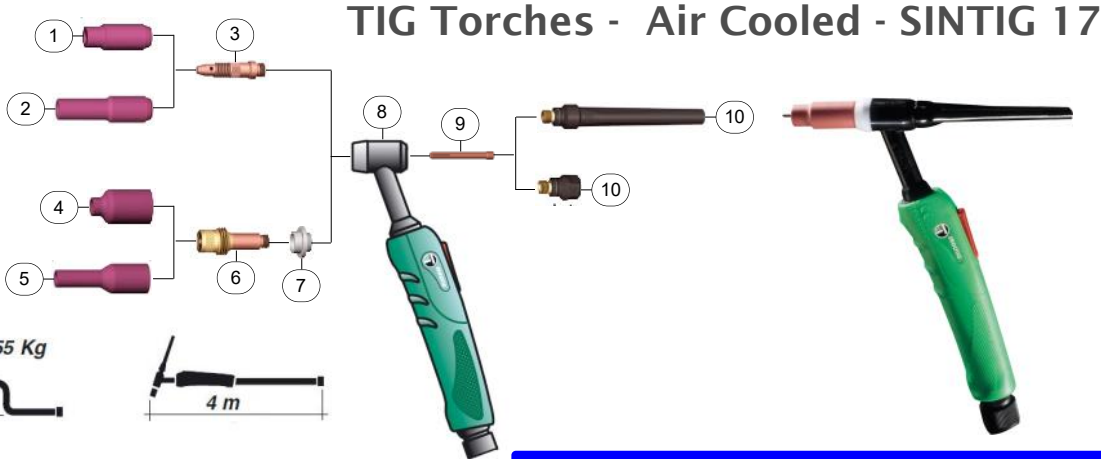

Advantageous

- The best known and used Tig torch in the world
- High quality and technology for trouble free performance whatever the welding jobs are
- Very flexible welding cable with high insulation level
- Wearing parts compatible with international standard
- Silicone Rubber torch bodies, reduce the possibility of accidental damage during use or the loss of high frequency signal due to torch body failure

Specifications

Type of Cooling	Air
Gas Flow	7 - 15 l/min
Duty Cycle 35 % DC	140 A
Duty Cycle 35 % AC	125 A
Tungsten Electrode Ø	1.6 - 2.4 mm

Pos	Item Code	Item Name	MoQ	
1	203.17.001	Alumina Nozzle Short No. 5 (10N49) - TIG 17 - 26 - 18	10 Pcs	
	203.17.002	Alumina Nozzle Short No. 6 (10N48) - TIG 17 - 26 - 18	10 Pcs	
	203.17.003	Alumina Nozzle Short No. 7 (10N47) - TIG 17 - 26 - 18	10 Pcs	
	203.17.004	Alumina Nozzle Short No. 8 (10N46) - TIG 17 - 26 - 18	10 Pcs	
	203.17.005	Alumina Nozzle Short No. 10 (10N45) - TIG 17 - 26 - 18	10 Pcs	
	203.17.006	Alumina Nozzle Short No. 12 (10N44) - TIG 17 - 26 - 18	10 Pcs	
2	203.18.001	Alumina Nozzle Long No. 5 (10N49L) - TIG 17 - 26 - 18	10 Pcs	
	203.18.002	Alumina Nozzle Long No. 6 (10N48L) - TIG 17 - 26 - 18	10 Pcs	
	203.18.003	Alumina Nozzle Long No. 7 (10N47L) - TIG 17 - 26 - 18	10 Pcs	
	3	203.22.001	Collet Body Ø 1.6 mm (10N31) - TIG 17 - 26 - 18	3 Pcs
		203.22.002	Collet Body Ø 2.4 mm (10N32) - TIG 17 - 26 - 18	3 Pcs
		4	203.19.001	Alumina Nozzle Short Gas Lens No. 4 (54N18) - TIG 17 - 26 - 18
203.19.002	Alumina Nozzle Short Gas Lens No. 5 (54N17) - TIG 17 - 26 - 18		10 Pcs	
203.19.003	Alumina Nozzle Short Gas Lens No. 6 (54N16) - TIG 17 - 26 - 18		10 Pcs	
203.19.004	Alumina Nozzle Short Gas Lens No. 7 (54N15) - TIG 17 - 26 - 18		10 Pcs	
203.19.005	Alumina Nozzle Short Gas Lens No. 8 (54N14) - TIG 17 - 26 - 18		10 Pcs	
203.19.006	Alumina Nozzle Short Gas Lens No. 12 (54N19) - TIG 17 - 26 - 18		10 Pcs	
5	203.20.001	Alumina Nozzle Long Gas Lens No. 5 (54N17L) - TIG 17 - 26 - 18	10 Pcs	
	203.20.002	Alumina Nozzle Long Gas Lens No. 6 (54N16L) - TIG 17 - 26 - 18	10 Pcs	
	203.20.003	Alumina Nozzle Long Gas Lens No. 7 (54N15L) - TIG 17 - 26 - 18	10 Pcs	
6	203.23.001	Collet Body Gas Lens Ø 1.6 mm (45V25) - TIG 17 - 26 - 18	3 Pcs	
	203.23.002	Collet Body Gas Lens Ø 2.4 mm (45V26) - TIG 17 - 26 - 18	3 Pcs	
7	203.23.005	Collet Body Gas Lens Insulator (54N01) - TIG 17 - 26 - 18	3 Pcs	
	8	203.32.007	Torch Head SINTIG 17	1 Pc
203.32.008		Torch Head Flexible SINTIG 17	1 Pc	
9	203.21.001	Collet Ø 1.6 mm (10N23) - TIG 17 - 26 - 18	5 Pcs	
	203.21.002	Collet Ø 2.4 mm (10N24) - TIG 17 - 26 - 18	5 Pcs	
10	203.24.001	Back Cap Long (57Y02) - TIG 17 - 26 - 18	3 Pcs	
	203.24.002	Back Cap Short (57Y04) - TIG 17 - 26 - 18	3 Pcs	

Recommended

1 Kobewel Solarmatic Helmet



2 DACH Tungsten Electrodes

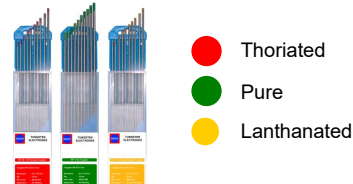

3 Inelco Tungsten Grinder



Item Code	Item Name	MoQ
203.16.007	TIG Torch - Air Cooled - SINTIG 17 at 4 m	1 Set
203.16.008	TIG Torch - Air Cooled - SINTIG 17 at 4 m - Flexible	1 Set
203.16.009	TIG Torch - Air Cooled - SINTIG 17 at 8 m	1 Set
203.16.021	TIG Torch - Air Cooled - SINTIG 17 at 8 m - Flexible	1 Set

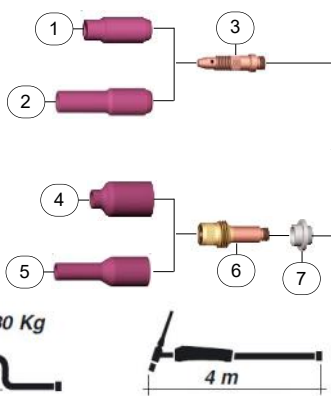

TIG Torches - Air Cooled - SINTIG 26

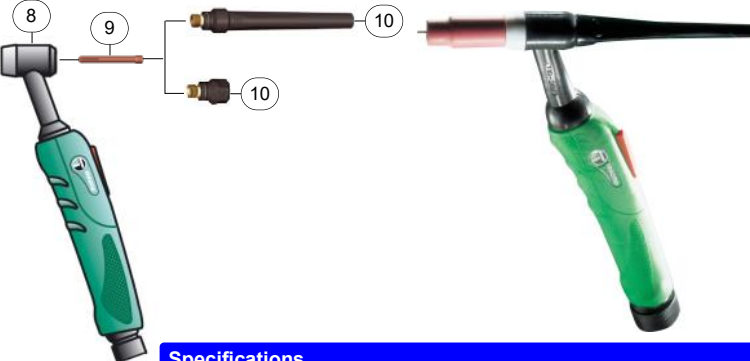

Advantageous

- The best known and used Tig torch in the world
- High quality and technology for trouble free performance whatever the welding jobs are
- Very flexible welding cable with high insulation level
- Wearing parts compatible with international standard
- Silicone Rubber torch bodies, reduce the possibility of accidental damage during use or the loss of high frequency signal due to torch body failure

Specifications

Type of Cooling	Air
Gas Flow	7 - 18 l/min
Duty Cycle 35 % DC	180 A
Duty Cycle 35 % AC	150 A
Tungsten Electrode Ø	1.6 - 4.0 mm

Pos	Item Code	Item Name	MoQ
1	203.17.001	Alumina Nozzle Short No. 5 (10N49) - TIG 17 - 26 - 18	10 Pcs
	203.17.002	Alumina Nozzle Short No. 6 (10N48) - TIG 17 - 26 - 18	10 Pcs
	203.17.003	Alumina Nozzle Short No. 7 (10N47) - TIG 17 - 26 - 18	10 Pcs
	203.17.004	Alumina Nozzle Short No. 8 (10N46) - TIG 17 - 26 - 18	10 Pcs
	203.17.005	Alumina Nozzle Short No. 10 (10N45) - TIG 17 - 26 - 18	10 Pcs
	203.17.006	Alumina Nozzle Short No. 12 (10N44) - TIG 17 - 26 - 18	10 Pcs
2	203.18.001	Alumina Nozzle Long No. 5 (10N49L) - TIG 17 - 26 - 18	10 Pcs
	203.18.002	Alumina Nozzle Long No. 6 (10N48L) - TIG 17 - 26 - 18	10 Pcs
	203.18.003	Alumina Nozzle Long No. 7 (10N47L) - TIG 17 - 26 - 18	10 Pcs
	203.18.004	Alumina Nozzle Long No. 12 (10N44L) - TIG 17 - 26 - 18	10 Pcs
3	203.22.001	Collet Body Ø 1.6 mm (10N31) - TIG 17 - 26 - 18	10 Pcs
	203.22.002	Collet Body Ø 2.4 mm (10N32) - TIG 17 - 26 - 18	3 Pcs
	203.22.003	Collet Body Ø 3.2 mm (10N28) - TIG 17 - 26 - 18	3 Pcs
	203.22.004	Collet Body Ø 4.0 mm (406488) - TIG 17 - 26 - 18	3 Pcs
4	203.19.001	Alumina Nozzle Short Gas Lens No. 4 (54N18) - TIG 17 - 26 - 18	3 Pcs
	203.19.002	Alumina Nozzle Short Gas Lens No. 5 (54N17) - TIG 17 - 26 - 18	10 Pcs
	203.19.003	Alumina Nozzle Short Gas Lens No. 6 (54N16) - TIG 17 - 26 - 18	10 Pcs
	203.19.004	Alumina Nozzle Short Gas Lens No. 7 (54N15) - TIG 17 - 26 - 18	10 Pcs
	203.19.005	Alumina Nozzle Short Gas Lens No. 8 (54N14) - TIG 17 - 26 - 18	10 Pcs
	203.19.006	Alumina Nozzle Short Gas Lens No. 12 (54N19) - TIG 17 - 26 - 18	10 Pcs
5	203.20.001	Alumina Nozzle Long Gas Lens No. 5 (54N17L) - TIG 17 - 26 - 18	10 Pcs
	203.20.002	Alumina Nozzle Long Gas Lens No. 6 (54N16L) - TIG 17 - 26 - 18	10 Pcs
	203.20.003	Alumina Nozzle Long Gas Lens No. 7 (54N15L) - TIG 17 - 26 - 18	10 Pcs
6	203.23.001	Collet Body Gas Lens Ø 1.6 mm (45V25) - TIG 17 - 26 - 18	10 Pcs
	203.23.002	Collet Body Gas Lens Ø 2.4 mm (45V26) - TIG 17 - 26 - 18	3 Pcs
	203.23.003	Collet Body Gas Lens Ø 3.2 mm (45V27) - TIG 17 - 26 - 18	3 Pcs
	203.23.004	Collet Body Gas Lens Ø 4.0 mm (45V28) - TIG 17 - 26 - 18	3 Pcs
7	203.23.005	Collet Body Gas Lens Insulator (54N01) - TIG 17 - 26 - 18	3 Pcs
8	203.32.009	Torch Head SINTIG 26	3 Pcs
	203.32.010	Torch Head Flexible SINTIG 26	1 Pc
9	203.21.001	Collet Ø 1.6 mm (10N23) - TIG 17 - 26 - 18	5 Pcs
	203.21.002	Collet Ø 2.4 mm (10N24) - TIG 17 - 26 - 18	5 Pcs
	203.21.003	Collet Ø 3.2 mm (10N25) - TIG 17 - 26 - 18	5 Pcs
	203.21.004	Collet Ø 4.0 mm (54N20) - TIG 17 - 26 - 18	5 Pcs
10	203.24.001	Back Cap Long (57Y02) - TIG 17 - 26 - 18	3 Pcs
	203.24.002	Back Cap Short (57Y04) - TIG 17 - 26 - 18	3 Pcs

Recommended

- 1 Kobewel Solarmatic Helmet



- 2 DACH Tungsten Electrodes

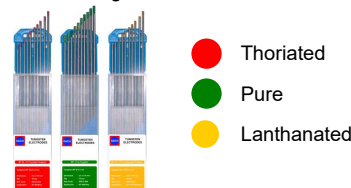

- 3 Inelco Tungsten Grinder



Item Code	Item Name	MoQ
203.16.010	TIG Torch - Air Cooled - SINTIG 26 at	1 Set
203.16.011	TIG Torch - Air Cooled - SINTIG 26 at	1 Set
203.16.012	TIG Torch - Air Cooled - SINTIG 26 at	1 Set
203.16.022	TIG Torch - Air Cooled - SINTIG 26 at	1 Set



TIG Torches - Water Cooled - SINTIG 18

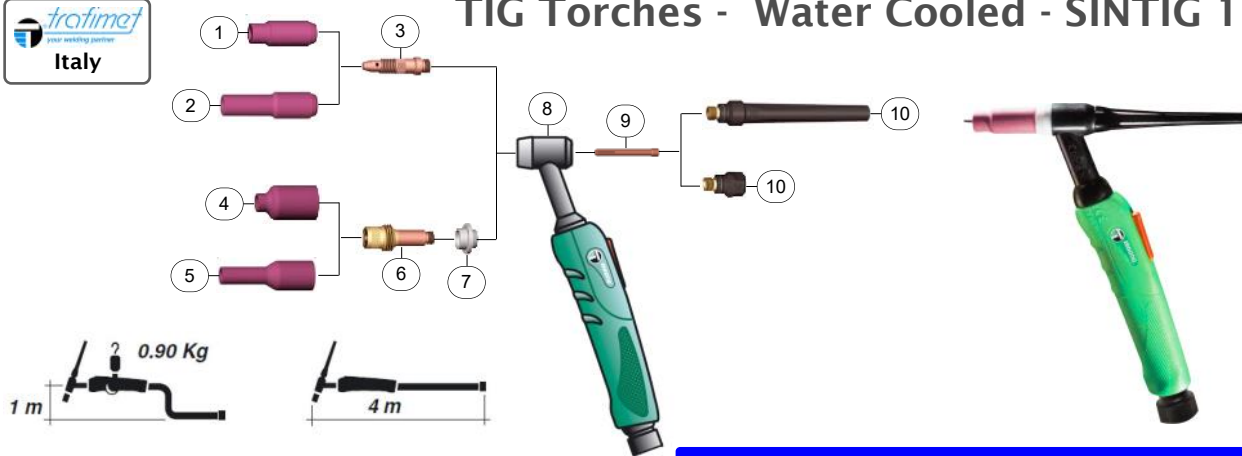

Advantageous

- The best known and used Tig torch in the world
- High quality and technology for trouble free performance whatever the welding jobs are
- Very flexible welding cable with high insulation level
- Wearing parts compatible with international standard
- Silicone Rubber torch bodies, reduce the possibility of accidental damage during use or the loss of high frequency signal due to torch body failure

Specifications

Type of Cooling	Water
Gas Flow	7 - 20 l/min
Duty Cycle 100 % DC	320 A
Duty Cycle 100 % AC	270 A
Tungsten Electrode Ø	1.6 - 4.0 mm
Max. Liquid Temp.	60 °C
Min. Liquid Flow Rate	1.5 l/min
Min. Liquid Pressure	2.0 Bar
Max. Liquid Pressure	4.0 Bar

Pos	Item Code	Item Name	MoQ
1	203.17.001	Alumina Nozzle Short No. 5 (10N49) - TIG 17 - 26 - 18	10 Pcs
	203.17.002	Alumina Nozzle Short No. 6 (10N48) - TIG 17 - 26 - 18	10 Pcs
	203.17.003	Alumina Nozzle Short No. 7 (10N47) - TIG 17 - 26 - 18	10 Pcs
	203.17.004	Alumina Nozzle Short No. 8 (10N46) - TIG 17 - 26 - 18	10 Pcs
	203.17.005	Alumina Nozzle Short No. 10 (10N45) - TIG 17 - 26 - 18	10 Pcs
	203.17.006	Alumina Nozzle Short No. 12 (10N44) - TIG 17 - 26 - 18	10 Pcs
2	203.18.001	Alumina Nozzle Long No. 5 (10N49L) - TIG 17 - 26 - 18	10 Pcs
	203.18.002	Alumina Nozzle Long No. 6 (10N48L) - TIG 17 - 26 - 18	10 Pcs
	203.18.003	Alumina Nozzle Long No. 7 (10N47L) - TIG 17 - 26 - 18	10 Pcs
3	203.22.001	Collet Body Ø 1.6 mm (10N31) - TIG 17 - 26 - 18	3 Pcs
	203.22.002	Collet Body Ø 2.4 mm (10N32) - TIG 17 - 26 - 18	3 Pcs
	203.22.003	Collet Body Ø 3.2 mm (10N28) - TIG 17 - 26 - 18	3 Pcs
	203.22.004	Collet Body Ø 4.0 mm (406488) - TIG 17 - 26 - 18	3 Pcs
4	203.19.001	Alumina Nozzle Short Gas Lens No. 4 (54N18) - TIG 17 - 26 - 18	10 Pcs
	203.19.002	Alumina Nozzle Short Gas Lens No. 5 (54N17) - TIG 17 - 26 - 18	10 Pcs
	203.19.003	Alumina Nozzle Short Gas Lens No. 6 (54N16) - TIG 17 - 26 - 18	10 Pcs
	203.19.004	Alumina Nozzle Short Gas Lens No. 7 (54N15) - TIG 17 - 26 - 18	10 Pcs
	203.19.005	Alumina Nozzle Short Gas Lens No. 8 (54N14) - TIG 17 - 26 - 18	10 Pcs
	203.19.006	Alumina Nozzle Short Gas Lens No. 12 (54N19) - TIG 17 - 26 - 18	10 Pcs
5	203.20.001	Alumina Nozzle Long Gas Lens No. 5 (54N17L) - TIG 17 - 26 - 18	10 Pcs
	203.20.002	Alumina Nozzle Long Gas Lens No. 6 (54N16L) - TIG 17 - 26 - 18	10 Pcs
	203.20.003	Alumina Nozzle Long Gas Lens No. 7 (54N15L) - TIG 17 - 26 - 18	10 Pcs
6	203.23.001	Collet Body Gas Lens Ø 1.6 mm (45V25) - TIG 17 - 26 - 18	3 Pcs
	203.23.002	Collet Body Gas Lens Ø 2.4 mm (45V26) - TIG 17 - 26 - 18	3 Pcs
	203.23.003	Collet Body Gas Lens Ø 3.2 mm (45V27) - TIG 17 - 26 - 18	3 Pcs
	203.23.004	Collet Body Gas Lens Ø 4.0 mm (45V28) - TIG 17 - 26 - 18	3 Pcs
7	203.23.005	Collet Body Gas Lens Insulator (54N01) - TIG 17 - 26 - 18	3 Pcs
8	203.32.011	Torch Head SINTIG 18	1 Pc
9	203.21.001	Collet Ø 1.6 mm (10N23) - TIG 17 - 26 - 18	5 Pcs
	203.21.002	Collet Ø 2.4 mm (10N24) - TIG 17 - 26 - 18	5 Pcs
	203.21.003	Collet Ø 3.2 mm (10N25) - TIG 17 - 26 - 18	5 Pcs
	203.21.004	Collet Ø 4.0 mm (54N20) - TIG 17 - 26 - 18	5 Pcs
10	203.24.001	Back Cap Long (57Y02) - TIG 17 - 26 - 18	3 Pcs
	203.24.002	Back Cap Short (57Y04) - TIG 17 - 26 - 18	3 Pcs

Recommended

- 1 Kobewel Solarmatic Helmet



- 2 DACH Tungsten Electrodes

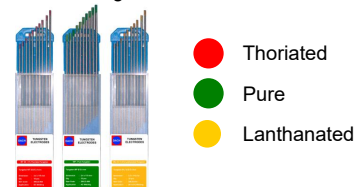

- 3 Inelco Tungsten Grinder



Item Code	Item Name	MoQ
203.16.013	TIG Torch - Water Cooled - SINTIG 18 at 4 m	1 Set
203.16.014	TIG Torch - Water Cooled - SINTIG 18 at 8 m	1 Set



TIG Torches - Air Cooled - SINTIG 9

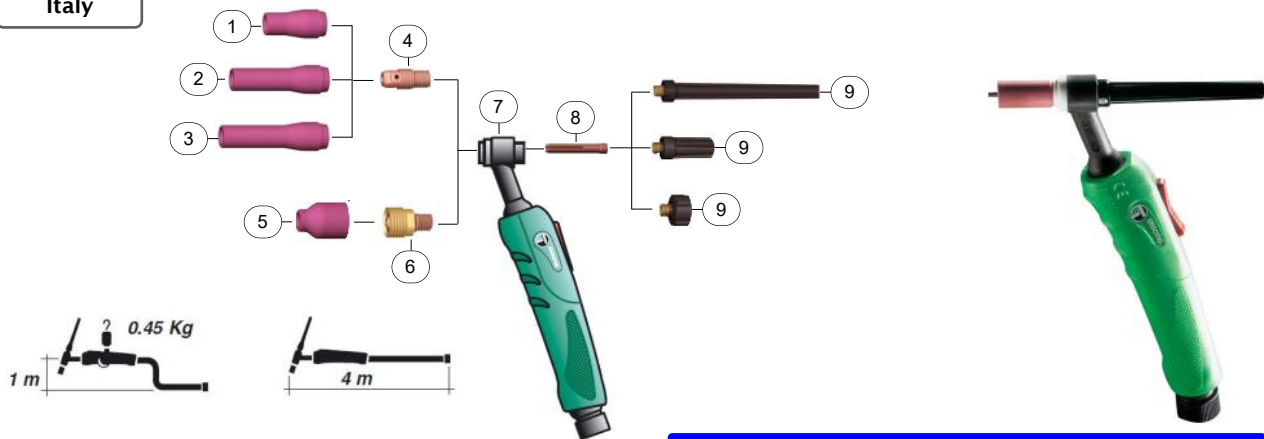

Advantageous

- The best known and used Tig torch in the world
- High quality and technology for trouble free performance whatever the welding jobs are
- Very flexible welding cable with high insulation level
- Wearing parts compatible with international standard
- Silicone Rubber torch bodies, reduce the possibility of accidental damage during use or the loss of high frequency signal due to torch body failure

Specifications

Type of Cooling	Air
Gas Flow	5 - 12 l/min
Duty Cycle 35 % DC	110 A
Duty Cycle 35 % AC	95 A
Tungsten Electrode Ø	2.4 mm

Pos	Item Code	Item Name	MoQ
1	203.25.001	Alumina Nozzle Short No. 4 (13N08) - TIG 9 - 20	10 Pcs
	203.25.002	Alumina Nozzle Short No. 5 (13N09) - TIG 9 - 20	10 Pcs
	203.25.003	Alumina Nozzle Short No. 6 (13N10) - TIG 9 - 20	10 Pcs
	203.25.004	Alumina Nozzle Short No. 7 (13N11) - TIG 9 - 20	10 Pcs
	203.25.005	Alumina Nozzle Short NO. 8 (13N12) - TIG 9 - 20	10 Pcs
	203.25.006	Alumina Nozzle Short No.10 (13N13) - TIG 9 - 20	10 Pcs
2	203.26.001	Alumina Nozzle Long No. 4 (796F71) - TIG 9 - 20	10 Pcs
	203.26.002	Alumina Nozzle Long No. 5 (796F71) - TIG 9 - 20	10 Pcs
	203.26.003	Alumina Nozzle Long No. 6 (796F73) - TIG 9 - 20	10 Pcs
3	203.26.004	Alumina Nozzle Extra Long No. 4 (796F75) - TIG 9 - 20	10 Pcs
	203.26.005	Alumina Nozzle Extra Long No. 5 (796F76) - TIG 9 - 20	10 Pcs
4	203.29.001	Collet Body Ø 1.6 mm (13N27) - TIG 9 - 20	3 Pcs
	203.29.002	Collet Body Ø 2.4 mm (13N28) - TIG 9 - 20	3 Pcs
5	203.27.001	Alumina Nozzle Short Gas Lens No. 4 (53N58) - TIG 9 - 20	10 Pcs
	203.27.002	Alumina Nozzle Short Gas Lens No. 5 (53N59) - TIG 9 - 20	10 Pcs
	203.27.003	Alumina Nozzle Short Gas Lens No. 6 (53N60) - TIG 9 - 20	10 Pcs
	203.27.004	Alumina Nozzle Short Gas Lens No. 7 (53N61) - TIG 9 - 20	10 Pcs
6	203.30.001	Collet Body Gas Lens Ø 1.6 mm (45V43) - TIG 9 - 20	3 Pcs
	203.30.002	Collet Body Gas Lens Ø 2.4 mm (45V44) - TIG 9 - 20	3 Pcs
7	203.32.012	Torch Head SINTIG 9	1 Pc
	203.32.013	Torch Head Flexible SINTIG 9	1 Pc
8	203.28.001	Collet Ø 1.6 mm (13N22) - TIG 9 - 20	5 Pcs
	203.28.002	Collet Ø 2.4 mm (13N23) - TIG 9 - 20	5 Pcs
9	203.31.001	Back Cap Long (41V24) - TIG 9 - 20	3 Pcs
	203.31.002	Back Cap Medium (41V35) - TIG 9 - 20	3 Pcs
	203.31.003	Back Cap Short (41V33) - TIG 9 - 20	3 Pcs

Recommended

- 1 Kobewel Solarmatic Helmet



- 2 DACH Tungsten Electrodes

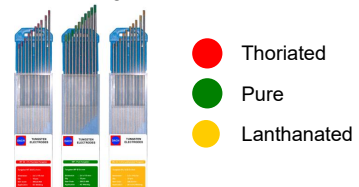

- 3 Inelco Tungsten Grinder



Item Code	Item Name	MoQ
203.16.015	TIG Torch - Air Cooled - SINTIG 9 at 4 m	1 Set
203.16.016	TIG Torch - Air Cooled - SINTIG 9 at 4 m - Flexible	1 Set



TIG Torch - Water Cooled - SINTIG 20

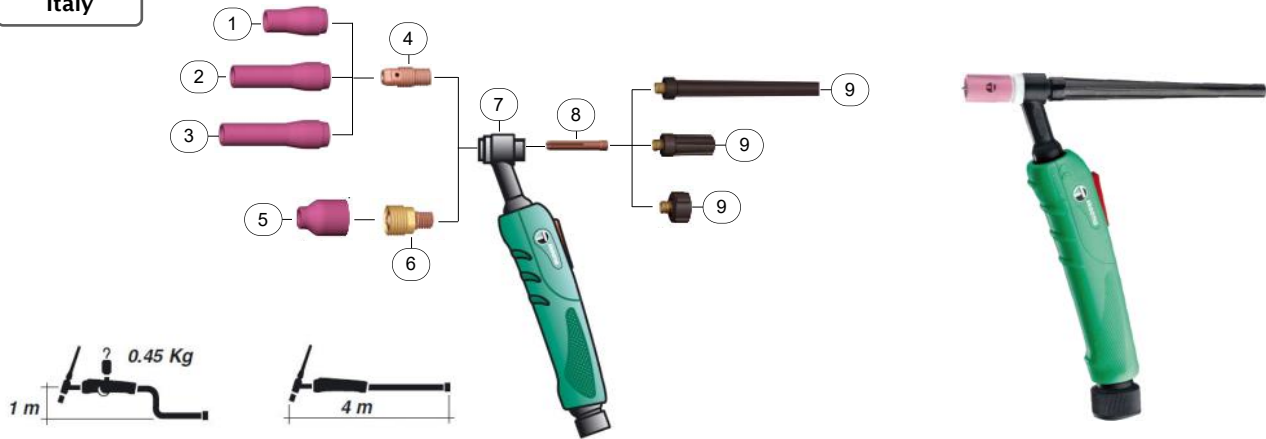

Advantageous

- The best known and used Tig torch in the world
- High quality and technology for trouble free performance whatever the welding jobs are
- Very flexible welding cable with high insulation level
- Wearing parts compatible with international standard
- Silicone Rubber torch bodies, reduce the possibility of accidental damage during use or the loss of high frequency signal due to torch body failure

Specifications

Type of Cooling	Water
Gas Flow	7 - 18 l/min
Duty Cycle 100 % DC	250 A
Duty Cycle 100 % AC	220 A
Tungsten Electrode Ø	1.6 - 3.2 mm
Max. Liquid Temp.	60 °C
Min. Liquid Flow Rate	1.0 l/min
Min. Liquid Pressure	2.0 Bar
Max. Liquid Pressure	4.0 Bar

Pos	Item Code	Item Name	MoQ
1	203.25.001	Alumina Nozzle Short No. 4 (13N08) - TIG 9 - 20	10 Pcs
	203.25.002	Alumina Nozzle Short No. 5 (13N09) - TIG 9 - 20	10 Pcs
	203.25.003	Alumina Nozzle Short No. 6 (13N10) - TIG 9 - 20	10 Pcs
	203.25.004	Alumina Nozzle Short No. 7 (13N11) - TIG 9 - 20	10 Pcs
	203.25.005	Alumina Nozzle Short No. 8 (13N12) - TIG 9 - 20	10 Pcs
	203.25.006	Alumina Nozzle Short No.10 (13N13) - TIG 9 - 20	10 Pcs
2	203.26.001	Alumina Nozzle Long No. 4 (796F71) - TIG 9 - 20	10 Pcs
	203.26.002	Alumina Nozzle Long No. 5 (796F72) - TIG 9 - 20	10 Pcs
	203.26.003	Alumina Nozzle Long No. 6 (796F73) - TIG 9 - 20	10 Pcs
3	203.26.004	Alumina Nozzle Extra Long no. 4 (796F75) - TIG 9 - 20	10 Pcs
	203.26.005	Alumina Nozzle Extra Long no. 5 (796F76) - TIG 9 - 20	10 Pcs
4	203.29.001	Collet Body Ø 1.6 mm (13N27) - TIG 9 - 20	3 Pcs
	203.29.002	Collet Body Ø 2.4 mm (13N28) - TIG 9 - 20	3 Pcs
	203.29.003	Collet Body Ø 3.2 mm (13N29) - TIG 9 - 20	3 Pcs
5	203.27.001	Alumina Nozzle Short Gas Lens No. 4 (53N58) - TIG 9 - 20	10 Pcs
	203.27.002	Alumina Nozzle Short Gas Lens No. 5 (53N59) - TIG 9 - 20	10 Pcs
	203.27.003	Alumina Nozzle Short Gas Lens No. 6 (53N60) - TIG 9 - 20	10 Pcs
	203.27.004	Alumina Nozzle Short Gas Lens No. 7 (53N61) - TIG 9 - 20	10 Pcs
6	203.30.001	Collet Body Gas Lens Ø 1.6 mm (45V43) - TIG 9 - 20	3 Pcs
	203.30.002	Collet Body Gas Lens Ø 2.4 mm (45V44) - TIG 9 - 20	3 Pcs
	203.30.003	Collet Body Gas Lens Ø 3.2 mm (45V45) - TIG 9 - 20	3 Pcs
7	203.32.014	Torch Head SINTIG 20	1 Pc
8	203.28.001	Collet Ø 1.6 mm (13N22) - TIG 9 - 20	5 Pcs
	203.28.002	Collet Ø 2.4 mm (13N23) - TIG 9 - 20	5 Pcs
	203.28.003	Collet Ø 3.2 mm (13N24) - TIG 9 - 20	5 Pcs
9	203.31.001	Back Cap Long (41V24) - TIG 9 - 20	3 Pcs
	203.31.002	Back Cap Medium (41V35) - TIG 9 - 20	3 Pcs
	203.31.003	Back Cap Short (41V33) - TIG 9 - 20	3 Pcs

Recommended

- 1 Kobewel Solarmatic Helmet



- 2 DACH Tungsten Electrodes

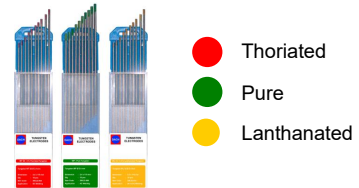

- 3 Inelco Tungsten Grinder



Item Code	Item Name	MoQ
203.16.017	TIG Torch - Water Cooled - SINTIG 20 at 4 m	1 Set



TIG Air Cooled Package



Advantageous

- High Quality Trafimet TIG torch for TIG Air Cooled packed in one with Trafimet Plug and Kobewel Regulator
- The Torch packed is 8 m, longer cable than Standard TIG Torch in the market.
- The torch installed with Plug already, cost effective for customer
- Created for TIG Welding Machine with Air Cooled

Item Code	Item Name	MoQ
Standard Accessories		
203.34.001	TIG Air Cooled Package with WP 17 V-25-2 at 8 m - 10-25	1 Set
203.16.003	WP 17 V-25-2 at 8 m	2 Pcs
203.01.004	Plug - Trak-SK 10-25 mm	2 Pcs
201.23.001	Argon Regulator	1 Pc
203.34.002	TIG Air Cooled Package with WP 17 V-25-2 at 8 m - 35-50	1 Set
203.16.003	WP 17 V-25-2 at 8 m	1 Pc
203.01.005	Plug - Trak-SK 35 mm	1 Pc
201.23.001	Argon Regulator	1 Pc
203.34.003	TIG Air Cooled Package with WP 26 V-25-2 at 8 m - 10-25	1 Set
203.16.005	WP 26 V-25-2 at 8 m	1 Pc
203.01.004	Plug - Trak-SK 10-25 mm	1 Pc
201.23.001	Argon Regulator	1 Pc
203.34.004	TIG Air Cooled Package with WP 26 V-25-2 at 8 m - 35-50	1 Set
203.16.005	WP 26 V-25-2 at 8 m	1 Pc
203.01.005	Plug - Trak-SK 35 mm	1 Pc
201.23.001	Argon Regulator	1 Pc

Recommended

- 1 Kobewel Solarmatic Helmet



- 2 DACH Tungsten Electrodes

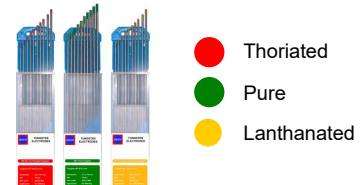

- 3 Inelco Tungsten Grinder





TIG Torch - Air Cooled - WP 17 V - 25 - 2

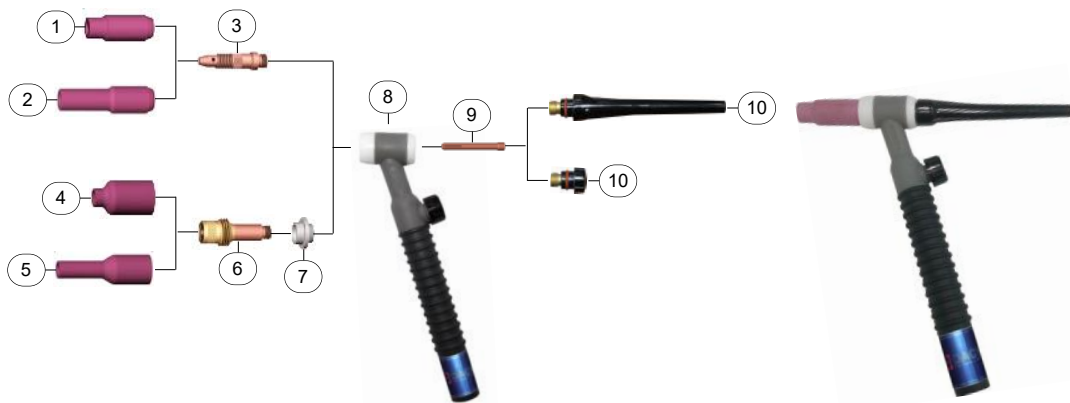

Advantageous

- Heavy and strong copper construction create better performance for job site work
- Easy and quick control on valve for gas shielding
- Ribbed handle for welding without any fatigue
- Very flexible welding cable with high insulation level
- Wearing parts compatible with international standard

Specifications

Type of Cooling	Air
Gas Flow	7 - 15 l/min
Duty Cycle 35 % DC	150 A
Duty Cycle 35 % AC	135 A
Tungsten Electrode Ø	1.6 - 2.4 mm

Pos	Item Code	Item Name	MoQ
1	203.17.001	Alumina Nozzle Short No. 5 (10N49) - TIG 17 - 26 - 18	10 Pcs
	203.17.002	Alumina Nozzle Short No. 6 (10N48) - TIG 17 - 26 - 18	10 Pcs
	203.17.003	Alumina Nozzle Short No. 7 (10N47) - TIG 17 - 26 - 18	10 Pcs
	203.17.004	Alumina Nozzle Short No. 8 (10N46) - TIG 17 - 26 - 18	10 Pcs
	203.17.005	Alumina Nozzle Short No. 10 (10N45) - TIG 17 - 26 - 18	10 Pcs
	203.17.006	Alumina Nozzle Short No. 12 (10N44) - TIG 17 - 26 - 18	10 Pcs
2	203.18.001	Alumina Nozzle Long No. 5 (10N49L) - TIG 17 - 26 - 18	10 Pcs
	203.18.002	Alumina Nozzle Long No. 6 (10N48L) - TIG 17 - 26 - 18	10 Pcs
	203.18.003	Alumina Nozzle Long No. 7 (10N47L) - TIG 17 - 26 - 18	10 Pcs
3	203.22.001	Collet Body Ø 1.6 mm (10N31) - TIG 17 - 26 - 18	3 Pcs
	203.22.002	Collet Body Ø 2.4 mm (10N32) - TIG 17 - 26 - 18	3 Pcs
4	203.19.001	Alumina Nozzle Short Gas Lens No. 4 (54N18) - TIG 17 - 26 - 18	10 Pcs
	203.19.002	Alumina Nozzle Short Gas Lens No. 5 (54N17) - TIG 17 - 26 - 18	10 Pcs
	203.19.003	Alumina Nozzle Short Gas Lens No. 6 (54N16) - TIG 17 - 26 - 18	10 Pcs
	203.19.004	Alumina Nozzle Short Gas Lens No. 7 (54N15) - TIG 17 - 26 - 18	10 Pcs
	203.19.005	Alumina Nozzle Short Gas Lens No. 8 (54N14) - TIG 17 - 26 - 18	10 Pcs
	203.19.006	Alumina Nozzle Short Gas Lens No. 12 (54N19) - TIG 17 - 26 - 18	10 Pcs
5	203.20.001	Alumina Nozzle Long Gas Lens No. 5 (54N17L) - TIG 17 - 26 - 18	10 Pcs
	203.20.002	Alumina Nozzle Long Gas Lens No. 6 (54N16L) - TIG 17 - 26 - 18	10 Pcs
	203.20.003	Alumina Nozzle Long Gas Lens No. 7 (54N15L) - TIG 17 - 26 - 18	10 Pcs
6	203.23.001	Collet Body Gas Lens Ø 1.6 mm (45V25) - TIG 17 - 26 - 18	3 Pcs
	203.23.002	Collet Body Gas Lens Ø 2.4 mm (45V26) - TIG 17 - 26 - 18	3 Pcs
7	203.23.005	Collet Body Gas Lens Insulator (54N01) - TIG 17 - 26 - 18	3 Pcs
8	203.32.003	Torch Head WP 17V	1 Pc
	203.32.004	Torch Head Flexible WP 17 FV	1 Pc
9	203.21.001	Collet Ø 1.6 mm (10N23) - TIG 17 - 26 - 18	5 Pcs
	203.21.002	Collet Ø 2.4 mm (10N24) - TIG 17 - 26 - 18	5 Pcs
10	203.24.001	Back Cap Long (57Y02) - TIG 17 - 26 - 18	3 Pcs
	203.24.002	Back Cap Short (57Y04) - TIG 17 - 26 - 18	3 Pcs

Recommended

- 1 Kobewel Solarmatic Helmet



- 2 DACH Tungsten Electrodes

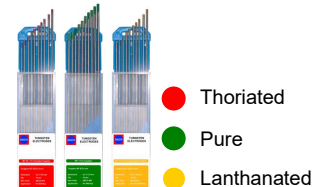

- 3 Inelco Tungsten Grinder



Item Code	Item Name	MoQ
208.17.006	TIG Torch - Air Cooled - WP 17 V-25-2 at 8 m	1 Set
208.17.008	TIG Torch - Air Cooled - WP 17 V-25-2 at 8 m Flexible	1 Set



TIG Torch - Air Cooled - WP 26 V - 25 - 2

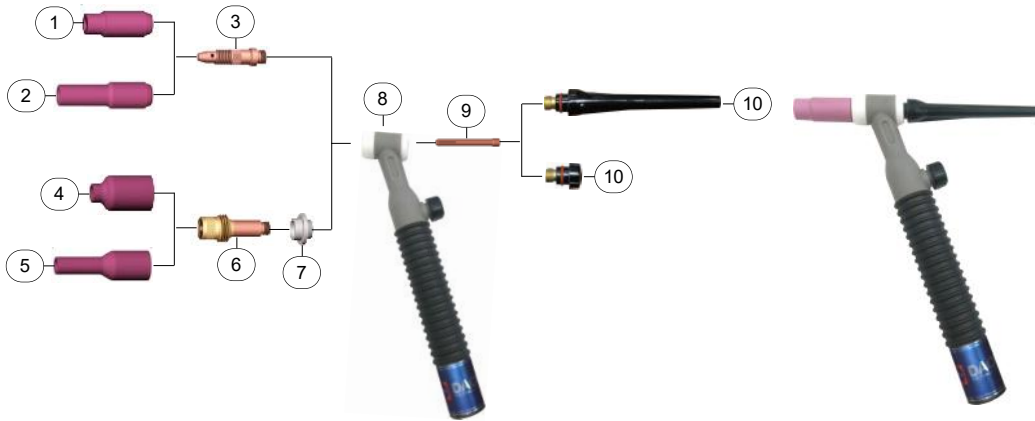

Advantageous

- Heavy and strong copper construction create better performance for job site work
- Easy and quick control on valve for gas shielding
- Ribbed handle for welding without any fatigue
- Very flexible welding cable with high insulation level
- Wearing parts compatible with international standard

Specifications

Type of Cooling	Air
Gas Flow	7 - 18 l/min
Duty Cycle 35 % DC	200 A
Duty Cycle 35 % AC	165 A
Tungsten Electrode Ø	1.6 - 4.0 mm

Pos	Item Code	Item Name	MoQ
1	203.17.001	Alumina Nozzle Short No. 5 (10N49) - TIG 17 - 26 - 18	10 Pcs
	203.17.002	Alumina Nozzle Short No. 6 (10N48) - TIG 17 - 26 - 18	10 Pcs
	203.17.003	Alumina Nozzle Short No. 7 (10N47) - TIG 17 - 26 - 18	10 Pcs
	203.17.004	Alumina Nozzle Short No. 8 (10N46) - TIG 17 - 26 - 18	10 Pcs
	203.17.005	Alumina Nozzle Short No. 10 (10N45) - TIG 17 - 26 - 18	10 Pcs
2	203.18.001	Alumina Nozzle Long No. 5 (10N49L) - TIG 17 - 26 - 18	10 Pcs
	203.18.002	Alumina Nozzle Long No. 6 (10N48L) - TIG 17 - 26 - 18	10 Pcs
	203.18.003	Alumina Nozzle Long No. 7 (10N47L) - TIG 17 - 26 - 18	10 Pcs
3	203.22.001	Collet Body Ø 1.6 mm (10N31) - TIG 17 - 26 - 18	3 Pcs
	203.22.002	Collet Body Ø 2.4 mm (10N32) - TIG 17 - 26 - 18	3 Pcs
	203.22.003	Collet Body Ø 3.2 mm (10N28) - TIG 17 - 26 - 18	3 Pcs
	203.22.004	Collet Body Ø 4.0 mm (406488) - TIG 17 - 26 - 18	3 Pcs
4	203.19.001	Alumina Nozzle Short Gas Lens No. 4 (54N18) - TIG 17 - 26 - 18	10 Pcs
	203.19.002	Alumina Nozzle Short Gas Lens No. 5 (54N17) - TIG 17 - 26 - 18	10 Pcs
	203.19.003	Alumina Nozzle Short Gas Lens No. 6 (54N16) - TIG 17 - 26 - 18	10 Pcs
	203.19.004	Alumina Nozzle Short Gas Lens No. 7 (54N15) - TIG 17 - 26 - 18	10 Pcs
	203.19.005	Alumina Nozzle Short Gas Lens No. 8 (54N14) - TIG 17 - 26 - 18	10 Pcs
	203.19.006	Alumina Nozzle Short Gas Lens No. 12 (54N19) - TIG 17 - 26 - 18	10 Pcs
5	203.20.001	Alumina Nozzle Long Gas Lens No. 5 (54N17L) - TIG 17 - 26 - 18	10 Pcs
	203.20.002	Alumina Nozzle Long Gas Lens No. 6 (54N16L) - TIG 17 - 26 - 18	10 Pcs
	203.20.003	Alumina Nozzle Long Gas Lens No. 7 (54N15L) - TIG 17 - 26 - 18	10 Pcs
6	203.23.001	Collet Body Gas Lens Ø 1.6 mm (45V25) - TIG 17 - 26 - 18	3 Pcs
	203.23.002	Collet Body Gas Lens Ø 2.4 mm (45V26) - TIG 17 - 26 - 18	3 Pcs
	203.23.003	Collet Body Gas Lens Ø 3.2 mm (45V27) - TIG 17 - 26 - 18	3 Pcs
	203.23.004	Collet Body Gas Lens Ø 4.0 mm (45V28) - TIG 17 - 26 - 18	3 Pcs
7	203.23.005	Collet Body Gas Lens Insulator (54N01) - TIG 17 - 26 - 18	3 Pcs
8	203.32.005	Torch Head WP 26 V	1 Pc
	203.32.006	Torch Head Flexible WP 26 FV	1 Pc
9	203.21.001	Collet Ø 1.6 mm (10N23) - TIG 17 - 26 - 18	5 Pcs
	203.21.002	Collet Ø 2.4 mm (10N24) - TIG 17 - 26 - 18	5 Pcs
	203.21.003	Collet Ø 3.2 mm (10N25) - TIG 17 - 26 - 18	5 Pcs
	203.21.004	Collet Ø 4.0 mm (54N20) - TIG 17 - 26 - 18	5 Pcs
10	203.24.001	Back Cap Long (57Y02) - TIG 17 - 26 - 18	3 Pcs
	203.24.002	Back Cap Short (57Y04) - TIG 17 - 26 - 18	3 Pcs

Recommended

1 Kobewel Solarmatic Helmet



2 DACH Tungsten Electrodes

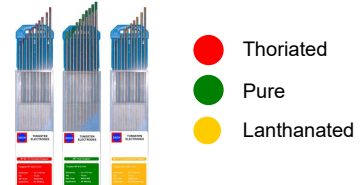

3 Inelco Tungsten Grinder



Item Code	Item Name	MoQ
208.17.007	TIG Torch - Air Cooled - WP 26 V-25-2 at 8 m	1 Set
208.17.009	TIG Torch - Air Cooled - WP 26 V-25-2 at 8 m Flexible	1 Set



ANSI / AWS A5.12M - 98
ISO 6848

Tungsten



Advantageous

- 2% thoriated tungsten contain a nominal 2 wt % of thorium oxide (ThO₂)
- The most common type of electrode used today
- Provides excellent resistance from weld pool contamination
- offers the welder easier arc starting capabilities and a more stable arc
- Generally used for DC electrode negative or straight polarity applications such as Carbon, Stainless steels, Nickel alloys and Titanium

● WT 20 : 2 % Thoriated Tungsten		
Item Code	Diameter	MoQ
208.23.001	1.6 mm	10 Pcs
208.23.002	2.4 mm	10 Pcs
208.23.003	3.2 mm	10 Pcs
208.23.004	4.0 mm	10 Pcs

Advantageous

- Contain a minimum of 99.5 wt % tungsten with no other alloying elements
- Allows the tip to form a clean, balled end which provides good arc stability
- Can be used with DC but not easy for arc starting
- Generally used in the welding of Aluminum and Magnesium alloys (AC)

● WP : Pure Tungsten		
Item Code	Diameter	MoQ
208.23.005	1.6 mm	10 Pcs
208.23.006	2.4 mm	10 Pcs
208.23.007	3.2 mm	10 Pcs
208.23.008	4.0 mm	10 Pcs

Advantageous

- Similar to Thoriated Tungsten
- Welders can easily replace the radioactive material from Thoriated with this tungsten without changing welding programs
- Less tip erosion
- Suitable for DC and AC Welding

● WL 15 : 1.5 % Lanthanated Tungsten		
Item Code	Diameter	MoQ
208.23.009	1.6 mm	10 Pcs
208.23.010	2.4 mm	10 Pcs
208.23.011	3.2 mm	10 Pcs



Tungsten Grinder - 240V-50/60HZ



Advantageous

- Perfect tungsten electrode grinding for perfect arc ignition and stability
- Grinding electrodes with dia. from 1.0 - 4.0 mm
- Variable angle adjustment from 15° to 180°
- If it is necessary to grind electrodes shorter in length than 15 mm, a special electrode clamp can be supplied
- equipped with an inspection cover enabling the operator to see the grinding operation
- equipped with an eccentric plate, which makes it possible to adjust the grinding position on the face of the wheel, this triples the life of the diamond wheel.
- Integrated filter dust to remove the grinding dust and the filter is replaceable
- Can achieve an exact and longitudinal ground tip
- Precise feeding of the tungsten to ensure a precision grinding tip geometry
- Clear view of the grinding process
- Single point adjustment

Specifications

Motor	650 Watt
Power	230V, 50 Hz
Rpm	28.000
Weight	2.8 kg
Filter	Inhalation filter
Diamond Wheel	Ø 40 mm

Attention, In-correct and precise tip, may cause

- Inductive interference
- Arc ignition problems
- Arc instability

Item Code	Item Name	MoQ
137.01.001	Tungsten Grinder - 240V-50/60HZ	1 Set

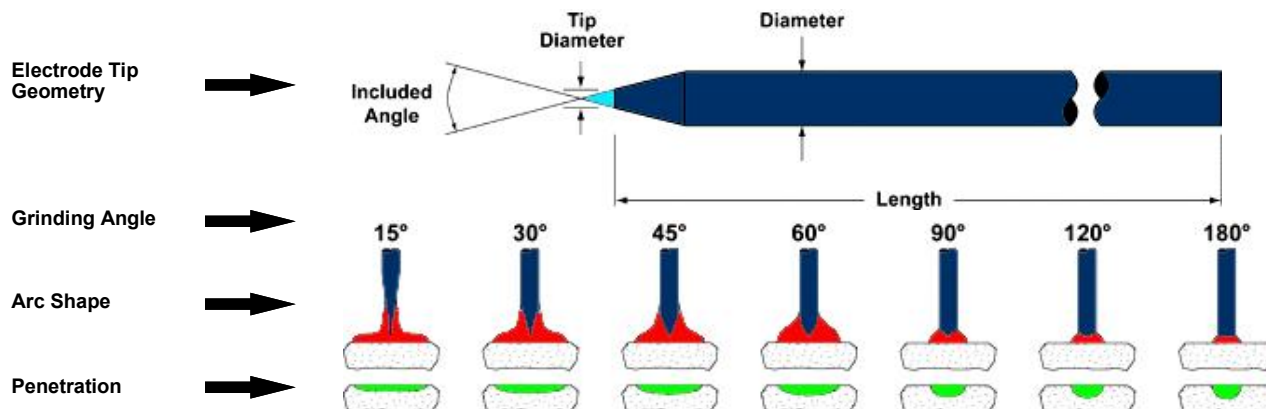



Plasma Cutting Torch - Ergocut CB50 - 6m - 1/4G

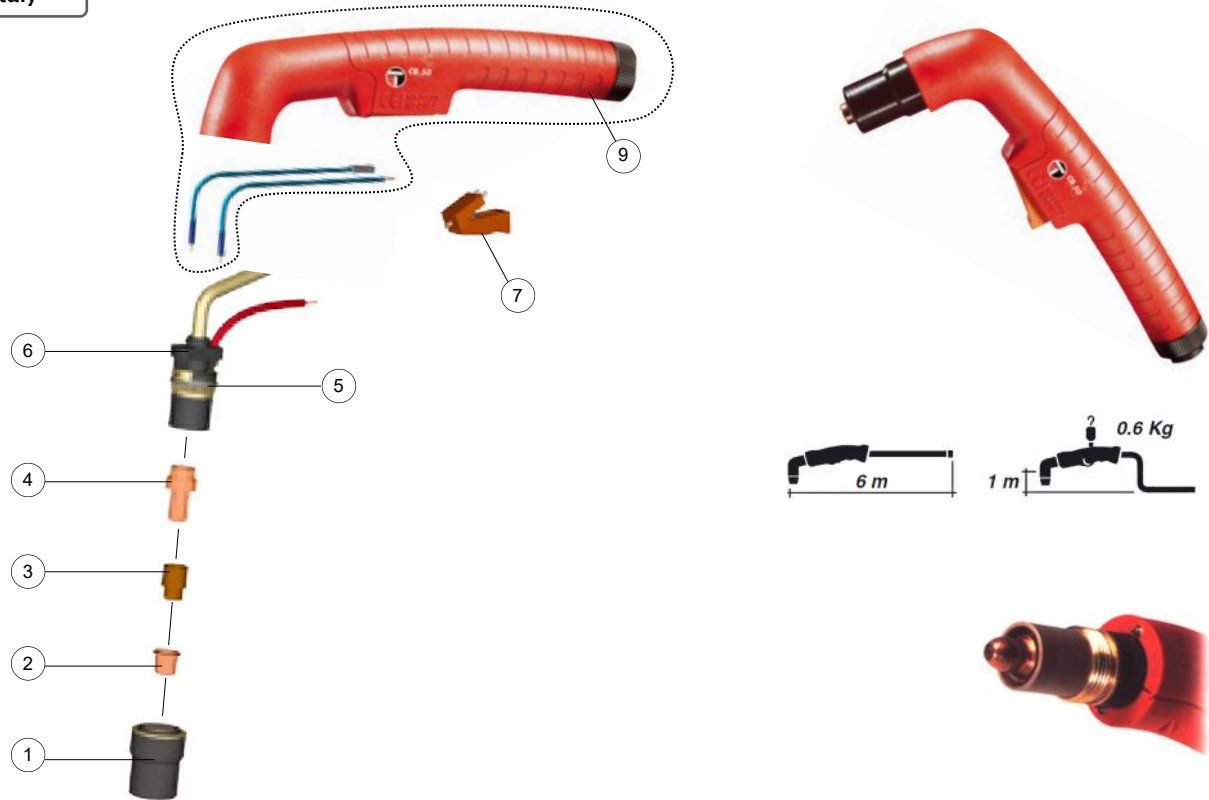

Advantageous

- HF Plasma cutting torch technology
- Torch body protected by the outer handle
- Highly flexible cable
- Electrical safety device built into the handle and easily replaceable
- Low cost of components
- Dimensions and weight reduced up to 30% less than traditional torches
- Electrical Safety, the spring pins, which control electrical safety with the nozzle open, are no longer built into the torch body but inserted in the handle. So to change a single pin, it is no longer necessary to replace the whole torch head

Pos	Item Code	Item Name	MoQ
1	203.35.003	Outside Nozzle - Ergocut CB50	1 Pc
2	203.35.004	Tip Ø 1.0 mm Long Life - Ergocut CB50	10 Pcs
	203.35.005	Tip Ø 1.1 mm Long Life - Ergocut CB50	10 Pcs
	203.35.006	Tip Ø 1.2 mm Long Life - Ergocut CB50	10 Pcs
3	203.35.007	Air Diffusor - Ergocut CB50	2 Pcs
4	203.35.008	Electrode-HF - Ergocut CB50	10 Pcs
5	203.35.009	O-Ring - Ergocut CB50	2 Pcs
6	203.35.010	Torch Head - Ergocut CB50	10 Pcs
7	203.35.011	Trigger - Ergocut CB50	1 Pc
8	203.35.002	Carriage - Ergocut CB50	1 Pc
9	203.35.012	Ergocut Handle - Ergocut CB50	1 Set
10	203.35.013	Flowmeter - Ergocut CB50	1 Pc

Specifications	
Severence Cutting	15 mm
Quality Cutting	10 mm
Voltage Class	M
Standard Length	6 m
Air Consumption	165 l/min
Air Pressure	5 bar
Duty cycle 60 %	50 A
Duty cycle 100 %	40 A

Item Code	Item Name	MoQ
203.35.001	Plasma Cutting Torch - Ergocut CB50 - 6m - 1/4G	1 Set
	• Flowmeter - Ergocut CB50	



Plasma Cutting Torch - Ergocut A81 - 6m - 1/4G

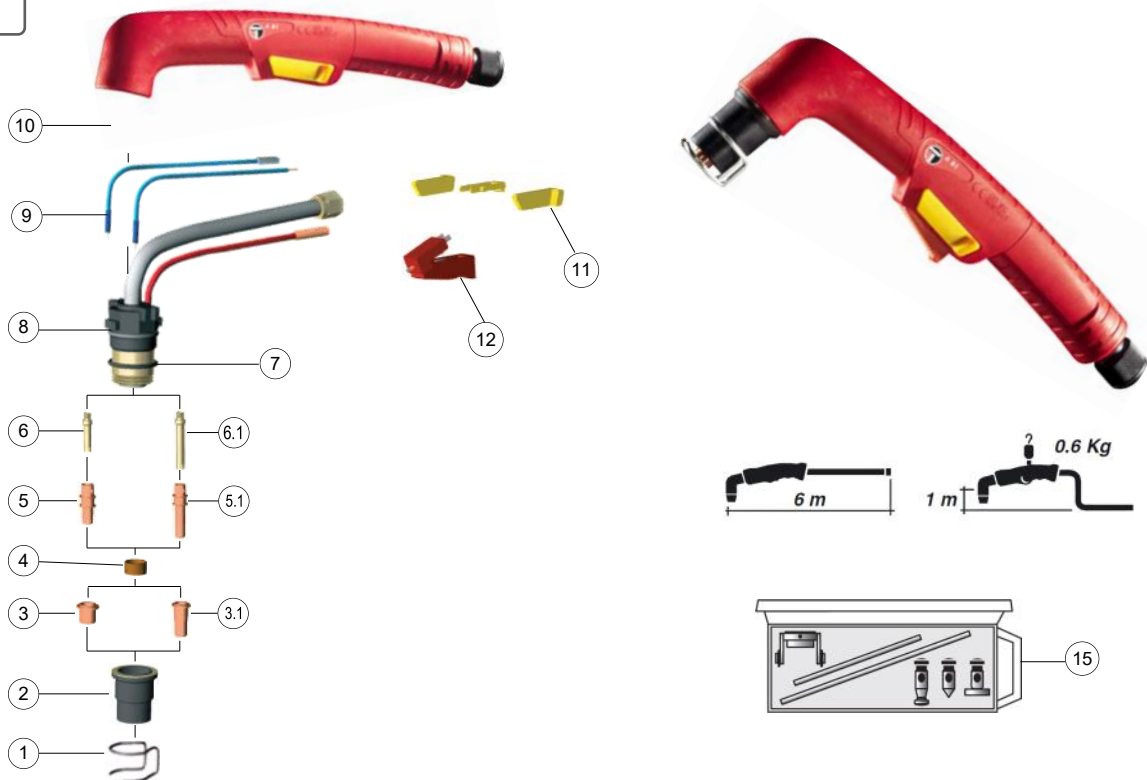

Advantageous

- Pilot arc Plasma cutting torch technology
- Protection, the torch head is integrated in the plastic handle
- Light Weight, the integration of the torch head in the handle has a lighter weight
- The ball and socket joint make the torch movement is more flexible
- Seal, provide an effective barrier against the entrance of cutting dust inside the handle
- Electrical Safety, the spring pins, which control electrical safety with the nozzle open, are no longer built into the torch body but inserted in the handle. So to change a single pin, it is no longer necessary to replace the whole torch head
- Ergocut handle is more ergonomic in the market today

Pos	Item Code	Item Name	MoQ
1	203.36.002	Stand Off Guide - Ergocut A81	5 Pcs
2	203.36.003	Outside Nozzle - Ergocut A81	5 Pcs / 10 Pcs
3	203.36.004	Tip Ø 1.0 mm - Ergocut A81	10 Pcs
	203.36.005	Tip Ø 1.2 mm - Ergocut A81	10 Pcs
3.1	203.36.008	Long Tip Ø 1.2 mm - Ergocut A81	10 Pcs
4	203.36.006	Air Diffuser - Ergocut A81	2 Pcs
5	203.36.007	Long Life Electrode - Ergocut A81	10 Pcs
5.1	203.36.009	Long Life Electrode , Long - Ergocut A81	10 Pcs
6	203.36.010	Diffuser - Ergocut A81	1 Pc
6.1	203.36.011	Long Diffuser - Ergocut A81	1 Pc
7	203.36.012	O-Ring - Ergocut A81	2 Pcs
8	203.36.013	Torch Head - Ergocut A81	1 Pc
9	203.36.014	Ergocut Handle Spring Pins Kit - Ergocut A81	1 Pc
10	203.36.015	Ergocut Handle - Ergocut A81	1 Pc
11	203.36.016	Key Safety Trigger - Ergocut A81	1 Pc
12	203.35.011	Trigger - Ergocut CB50 / A81	1 Pc
13	203.36.017	Carriage - Ergocut A81	1 Pc
14	203.36.018	Flowmeter - Ergocut A81	1 Pc
15	203.36.019	Circle Attachment - Ergocut A81 / A151	1 Pc

Specifications	
Severence Cutting	25 mm
Quality Cutting	20 mm
Voltage Class	M
Standard Length (m)	6
Air Consumption	155 l/min
Air Pressure	5 bar
Duty cycle 60 %	80 A
Duty cycle 100 %	60 A

Key safety Trigger, simple - immediate - reliable - evident - ambidextrous, these are the characteristics of the new safety device installed by Trafimet in ERGOCUT Torches for Plasma cutting, considering the more pressing demands for safety in the place of work.



Item Code	Item Name	MoQ
203.36.001	Plasma Cutting Torch - Ergocut A81 - 6m - 1/4G	1 Set
203.36.001.2	Plasma Cutting Torch Ergocut A81 - 6 m Central Adaptor	1 Set
	• Flowmeter - Ergocut A81	



Plasma Cutting Torch - Ergocut A151 - 6m - 1/4G

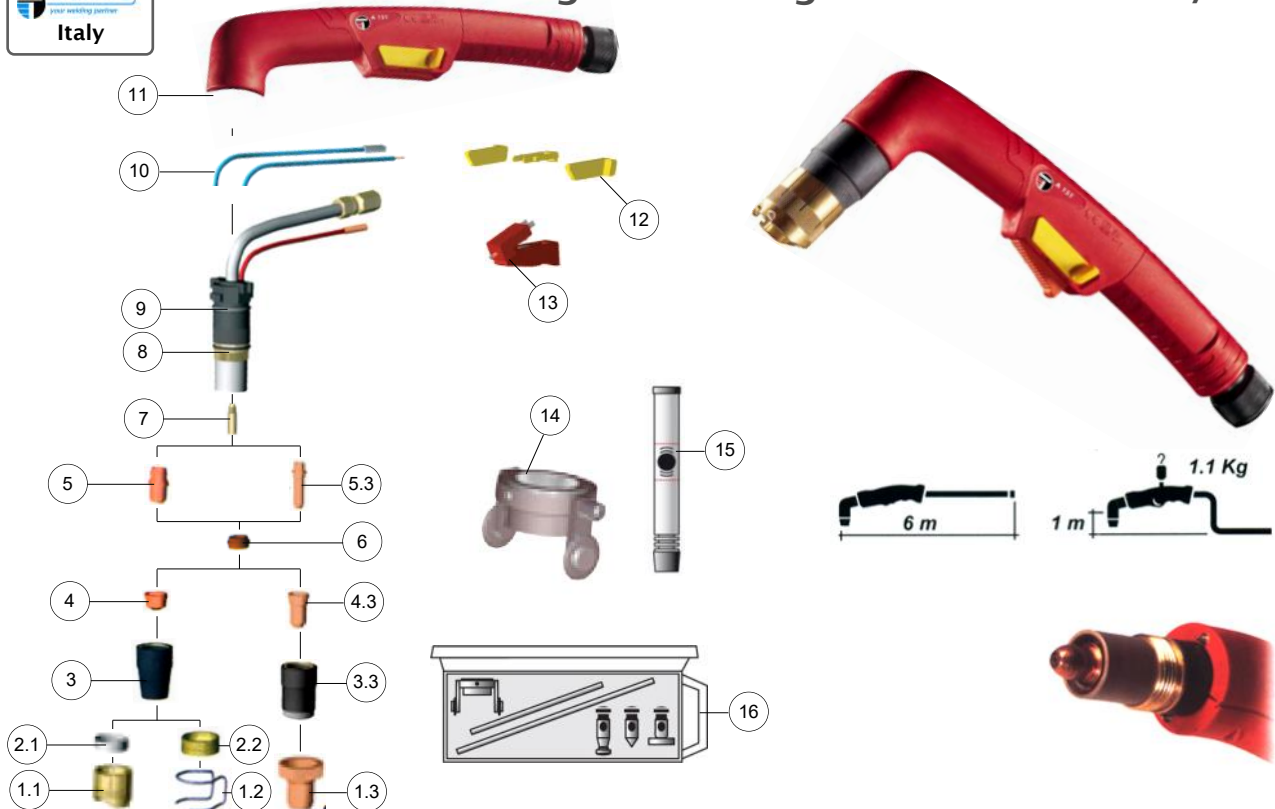

Advantageous

- Pilot arc Plasma cutting torch technology
- Protection, the torch head is integrated in the plastic handle
- Light Weight, the integration of the torch head in the handle has a lighter weight
- The ball and socket joint make the torch movement is more flexible
- Seal, provide an effective barrier against the entrance of cutting dust inside the handle
- Electrical Safety, the spring pins, which control electrical safety with the nozzle open, are no longer built into the torch body but inserted in the handle. So to change a single pin, it is no longer necessary to replace the whole torch head
- Ergocut handle is more ergonomic in the market today

Pos	Item Code	Item Name	MoQ
1.1	203.37.021	Stand Off Guide I - Ergocut A151	2 Pcs / 10 Pcs
2.1	203.37.020	Shield for Stand Off Guide - Ergocut A151	2 Pcs / 10 Pcs
1.2	203.37.002	Stand Off Guide - Ergocut A151	5 Pcs
2.2	203.37.004	Stand Off Guide Adaptor - Ergocut A151	2 Pcs
3	203.37.005	Outside Nozzle - Ergocut A151	2 Pcs
4	203.37.007	Tip Ø 1.4 mm - Ergocut A151	10 Pcs
	203.37.008	Tip Ø 1.6 mm - Ergocut A151	10 Pcs
	203.37.009	Tip Ø 1.8 mm - Ergocut A151	10 Pcs
	203.37.010	Tip Ø 3.0 mm - Ergocut A151	10 Pcs
5	203.37.013	Long Life Electrode - Ergocut A151	10 Pcs
6	203.37.012	Air -Diffuser - Ergocut A151	2 Pcs
7	203.37.015	Diffuser - Ergocut A151	1 Pc
8	203.37.016	O-Ring - Ergocut A151	2 Pcs
9	203.37.017	Torch Head - Ergocut A151	1 Pc
1.3	203.37.003	Contact Cutting Attachment - Ergocut A151	5 Pcs / 10 Pcs
3.3	203.37.006	Contact Cutting Nozzle Long Life - Ergocut A151	2 Pcs
4.3	203.37.011	Long Tip Ø 1.2 mm - Ergocut A151	10 Pcs
5.3	203.37.014	Long Life Electrode, Long - Ergocut A151	10 Pcs
10	203.36.014	Ergocut Handle Spring pins kit A81 / A151	1 Pc
11	203.36.015	Ergocut Handle A81 / A151	1 Pc
12	203.36.016	Key Safety Trigger A81 / A151	1 Pc
13	203.35.011	Trigger CB50 / A81 / A151	1 Pc
14	203.37.018	Carriage - Ergocut A151	1 Pc
15	203.37.019	Flowmeter - Ergocut A151	1 Pc
16	203.36.019	Circle Attachment A81 / A151 / AW201	1 Pc

Specifications	
Severence Cutting	50 mm
Quality Cutting	35 mm
Voltage Class	M
Standard Length	6 m
Air Consumption	230 l/min
Air Pressure	5 bar
Duty cycle 60 %	150 A
Duty cycle 100 %	120 A

Key safety Trigger, simple - immediate - reliable - evident - ambidextrous, these are the characteristics of the new safety device installed by Trafimet in ERGOCUT Torches for Plasma cutting, considering the more pressing demands for safety in the place of work.



Item Code	Item Name	MoQ
203.37.001	Plasma Cutting Torch - Ergocut A151 - 6m - 1/4G	1 Set
203.37.001.2	Plasma Cutting Torch Ergocut A151 - 6 m Central Adaptor	1 Set
	• Flowmeter - Ergocut A151	



Plasma Cutting Torch - Ergocut P151 - 6m - 1/4G - Autocut P151

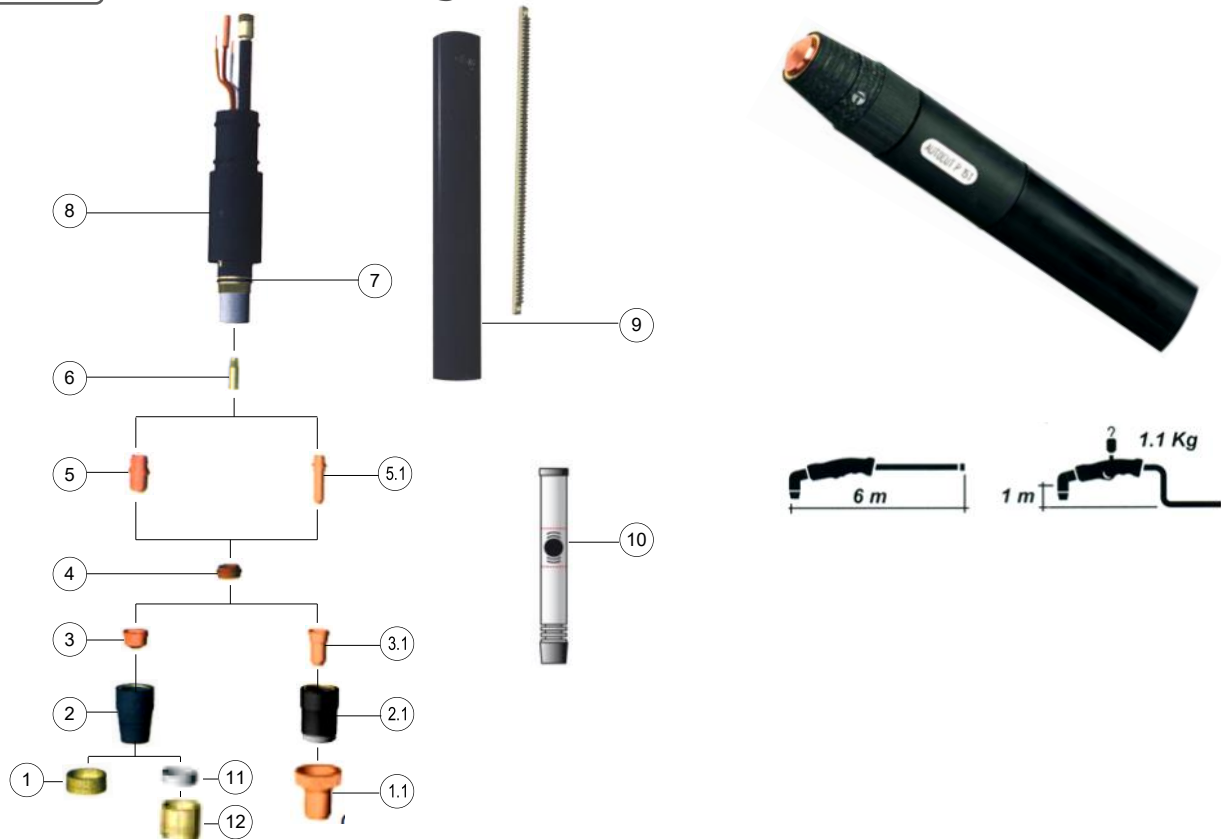

Advantageous

- Pilot arc Plasma cutting torch technology
- Protection, the torch head is integrated in the plastic handle.
- Light Weight, the integration of the torch head in the handle has a lighter weight.
- Seal, provide an effective barrier against the entrance of cutting dust inside the handle.

Pos	Item Code	Item Name	MoQ
1	203.37.004	Stand Off Guide Adaptor - Ergocut A151	5 Pcs
1.1	203.37.003	Contact Cutting Attachment - Ergocut A151	2 Pcs
2	203.37.005	Outside Nozzle - Ergocut A151	2 Pcs
2.1	203.37.006	Contact Cutting Nozzle Long Life - Ergocut A151	2 Pcs
3	203.37.007	Tip Ø 1.4 mm - Ergocut A151	10 Pcs
	203.37.008	Tip Ø 1.6 mm - Ergocut A151	10 Pcs
	203.37.009	Tip Ø 1.8 mm - Ergocut A151	10 Pcs
	203.37.010	Tip Ø 3.0 mm - Ergocut A151	10 Pcs
3.1	203.37.011	Long Tip Ø 1.2 mm - Ergocut A151	10 Pcs
4	203.37.012	Air - Diffusor - Ergocut A151	2 Pcs
5	203.37.013	Long Life Electrode - Ergocut A151	10 Pcs
5.1	203.37.014	Long Life Electrode, Long - Ergocut A151	10 Pcs
6	203.37.015	Diffuser - Ergocut A151	1 Pc
7	203.37.016	O-Ring - Ergocut A151	2 Pcs
8	203.38.003	Ergocut P151 - 6m - 1/4G - Torch Head	1 Pc
9	203.38.002	Ergocut P151 - 6m - 1/4G - Handle	1 Pc
10	203.37.019	Flowmeter - Ergocut A151	1 Pc
11	203.37.020	Shield for Stand Off Guide - Ergocut A151	1 Pc
12	203.37.021	Stand Off Guide I - Ergocut A151	1 Pc

Specifications	
Severence Cutting	50 mm
Quality Cutting	35 mm
Voltage Class	M
Standard Length (m)	6
Air Consumption	230 l/min
Air Pressure	5 bar
Duty cycle 60 %	150 A
Duty cycle 100 %	120 A

Item Code	Item Name	MoQ
203.38.001	Plasma Cutting Torch - Ergocut P151 - 6m - 1/4G - Autocut P151	1 Set
203.38.001.1	Ergocut P151 - 6 m Central Adaptor	1 Set
	• Flowmeter - Ergocut A151	



PSB 31 HFS

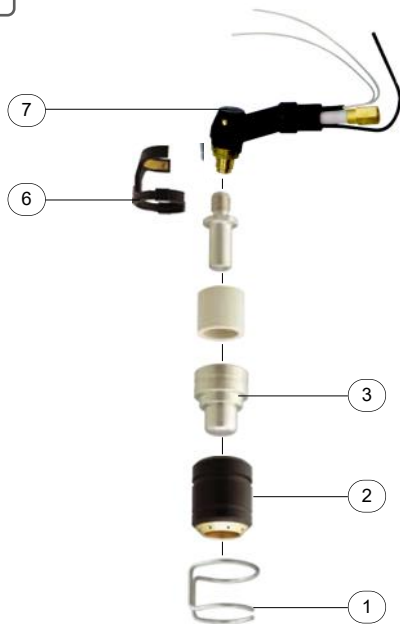

Advantageous

- A sturdy and reliable classical tool for manual cutting applications with safety switch
- PSB torch offers excellent cutting capability with long life wear parts
- The comfortable handle with optimises the distance to the plasma arc and offers, in combination with the light and flexible assembly, both ergonomic and safe working
- Effective air-cooling and an efficient combination of materials guarantees optimal heat dissipation and current transfer in a compact construction, thus improving accessibility

Specifications

Duty Cycle a 60 %	30 A
Plasma Gas Supply and Cooling Gas Supply	Compressed air
Max. Pressure	3.5 - 4.5 bar
Gas Flow	130 L / min
Air Post Flow	60 s
Ignition Voltage	7.000 volt
Cutting Thickness	10 mm

Pos.	Item Code	Item Name	MoQ
1	204.57.002	Spring	2 Pcs
2	204.57.007	Cap PSB 31 HFS	1 Pc
3	204.57.006	Plasma nozzle Ø 1.0 mm	5 Pcs
6	204.57.001	Safety clamp	1 Pc
7	204.58.005	Torch Body	1 Pc

Item Code	Item Name	MoQ
204.53.003	PSB 31 HFS	1 Set



Abiplas Cut 70

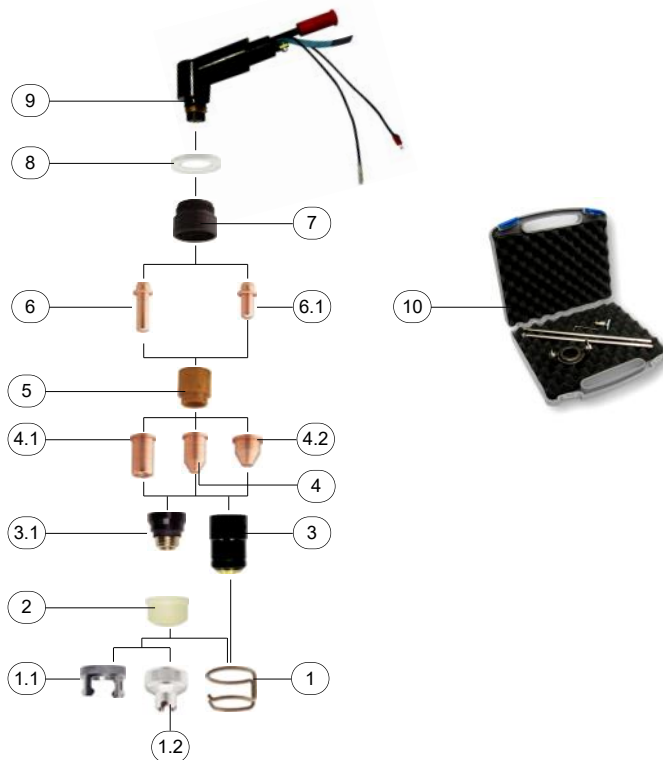

Advantageous

- Plasma cutting torches ABIPLASCUT from ABICOR BINZEL represent a new generation of equipment, combining the acknowledged design principles of BINZEL products with the latest technical know-how
- ABIPLAS CUT torches, available in different capacities, are of course reliable, offer excellent cutting capability with long life wear parts
- The comfortable handle with an extended trigger optimises the distance to the plasma arc and offers, in combination with the light and flexible assembly, both ergonomic and safe working
- Effective air-cooling and an efficient combination of materials guarantees optimal heat dissipation and current transfer in a compact construction, thus improving accessibility

Specifications

Duty Cycle at 60 %	70 A
Duty Cycle at 100 %	50 A
Plasma Gas Supply and Cooling Gas Supply	Compressed air
Max. Pressure	4.8 - 7 bar
Gas Flow	155 L / min
Air Post Flow	60 s
Ignition Voltage	7.000 volt
Cutting Thickness	15 mm at 50 A 25 mm at 70 A

Pos	Item Code	Item Name	MoQ
1	204.54.003	Distance Spring - ABC 70	2 Pcs
1.1	204.54.013	Bevel Cutting Nozzle = New - ABC 70	1 Pc
1.2	204.54.014	Castellated Nozzle Long = New - ABC 70	1 Pc
2	-	Spatter Guard	1 Pc
3	204.54.008	Shield Cap = Old - ABC 70	1 Pc
3.1	-	Cap Body	1 Pc
4	204.54.007	Nozzle Long, Ø 0.9 mm for 30 A - ABC 70	5 Pcs
	204.54.009	Nozzle Long Ø 1.1 mm for 30 - 50 A - ABC 70	5 Pcs
4.1	204.54.004	Plasma Nozzle Cross Groove long Ø 0.9 mm for 30A - ABC 70	5 Pcs
4.2	204.54.001	Plasma Nozzle Short Ø 0.9 mm - ABC 70	10 Pcs
	204.54.002	Plasma Nozzle Ø 1.1 mm - ABC 70	10 Pcs
	204.54.005	Plasma Nozzle Ø 1.2 mm - ABC 70	10 Pcs
5	204.54.012	Swirl Ring - ABC 70	2 Pcs
6	204.54.011	Electrode Long - ABC 70	5 Pcs
6.1	204.54.010	Electrode - ABC 70	5 Pcs
7	204.54.006	Insulator - ABC 70	2 Pcs
8	-	O-ring	5 Pcs
9	204.58.002	Torch Body Abiplast Cut 70	1 Pc
10	204.54.015	Torch carriage set for ABC 70	1 Set



Item Code	Item Name	MoQ
204.53.001	Abiplas Cut 70 at 6.0 m - Standard	1 Set



Abiplas Cut 110

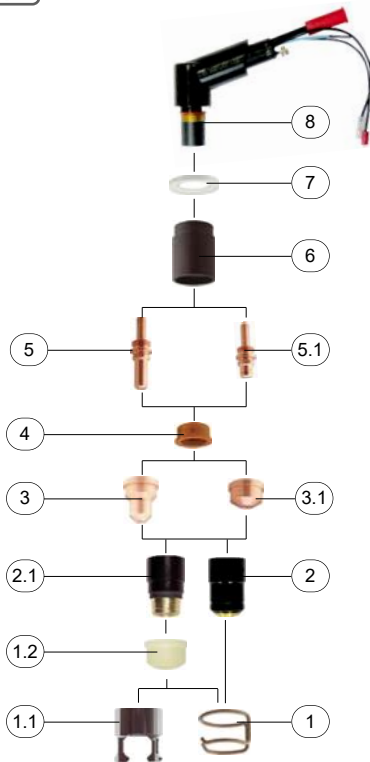

Advantageous

- Plasma cutting torches ABIPLASCUT from ABICOR BINZEL represent a new generation of equipment, combining the acknowledged design principles of BINZEL products with the latest technical know-how
- ABIPLAS CUT torches, available in different capacities, are of course reliable, offer excellent cutting capability with long life wear parts
- The comfortable handle with an extended trigger optimises the distance to the plasma arc and offers, in combination with the light and flexible assembly, both ergonomic and safe working
- Effective air-cooling and an efficient combination of materials guarantees optimal heat dissipation and current transfer in a compact construction, thus improving accessibility

Specifications

Duty Cycle at 60 %	110 A
Duty Cycle at 100 %	90 A
Plasma Gas Supply and Cooling Gas Supply	Compressed air
Max. Pressure	4.8 - 7 bar
Gas Flow	180 L / min
Air Post Flow	60 s
Ignition Voltage	7.000 volt
Cutting Thickness	35 mm at 90 A 40 mm at 110 A

Pos.	Item Code	Item Name	MoQ
1	204.62.001	Distance Spring - ABC 110 & 150	2 Pcs
1.1	204.62.002	Bevel Cutting Nozzle - ABC 110 & 150	1 Pc
1.2	-	Spatter Guard	1 Pc
2	204.55.007	Shield Cap - ABC 110	1 Pc
2.1	204.55.011	Cap Body - ABC 110	1 Pc
3	204.55.009	Plasma Nozzle with Cross Groove , long - ABC 110	5 Pcs
3.1	204.55.004	Plasma Nozzle Short 50 A Ø 1.0 mm - ABC 110	5 Pcs
	204.55.001	Plasma Nozzle 70 A dia 1.2 mm - ABC 110	5 Pcs
	204.55.003	Plasma Nozzle Short 90 A Ø 1.4 mm - ABC 110	5 Pcs
	204.55.008	Plasma Nozzle short 110 dia Ø 1.6 mm - ABC 110	5 Pcs
4	204.56.013	Swirl Ring - ABC 150	2 Pcs
5	204.55.002	Electrode, Long - ABC 110	5 Pcs
5.1	204.55.005	Electrode - ABC 110	5 Pcs
6	204.55.006	Insulator - ABC 110	1 Pc
7	-	O-ring	5 Pcs
8	204.58.001	Torch Body Abiplast Cut 110	1 Pc

Item Code	Item Name	MoQ
204.53.002	Abiplas Cut 110 at 6.0 m - Standard	1 Set





Abiplas Cut 150

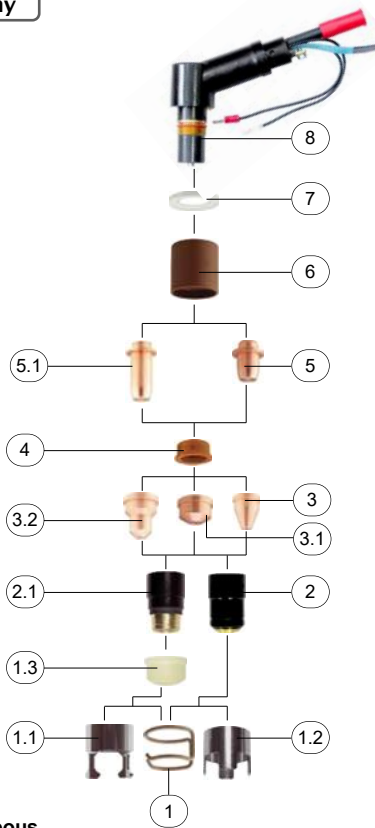

Advantageous

- Plasma cutting torches ABIPLASCUT from ABICOR BINZEL represent a new generation of equipment, combining the acknowledged design principles of BINZEL products with the latest technical know-how
- ABIPLAS CUT torches, available in different capacities, are of course reliable, offer excellent cutting capability with long life wear parts
- The comfortable handle with an extended trigger optimises the distance to the plasma arc and offers, in combination with the light and flexible assembly, both ergonomic and safe working
- Effective air-cooling and an efficient combination of materials guarantees optimal heat dissipation and current transfer in a compact construction, thus improving accessibility

Specifications

Duty Cycle at 60 %	150 A
Duty Cycle at 100 %	120 A
Plasma Gas Supply and Cooling Gas Supply	Compressed air
Max. Pressure	4.8 - 7 bar
Gas Flow	235 L / min
Air Post Flow	60 s
Ignition Voltage	7.000 volt
Cutting Thickness	45 mm at 120 A 55 mm at 150 A

Pos.	Item Code	Item Name	MoQ
1	204.62.001	Distance Spring - ABC 110 & 150	2 Pcs
1.1	204.62.002	Bevel Cutting Nozzle - ABC 110 & 150	1 Pc
1.2	204.56.010	Castellated Nozzle - ABC 150	1 Pc
1.3	-	Spatter Guard	1 Pc
2	204.56.009	Shield Cap - ABC 150	1 Pc
2.1	204.56.014	Cap Body - ABC 150	1 Pc
3	204.56.011	Plasma Nozzle Cross Groove Long D = 1.2/50A - ABC 150	5 Pcs
3.1	204.56.008	Plasma Nozzle Ø 1.2 / 70 A - ABC 150	5 Pcs
	204.56.003	Plasma Nozzle Ø 1.5 / 70 - 90 A - ABC 150	5 Pcs
	204.56.007	Plasma Nozzle Ø 1.6 / 90 - 120 A - ABC 150	5 Pcs
	204.56.004	Plasma Nozzle Ø 1.8 / 120 - 150 A - ABC 150	5 Pcs
3.2	204.56.005	Gouging Nozzle - ABC 150	1 Pc
4	204.56.013	Swirl Ring - ABC 150	2 Pcs
5	204.56.002	Electrode - ABC 150	5 Pcs
5.1	204.56.012	Electrode Long - ABC 150	5 Pcs
6	-	Insulator	1 Pc
7	204.56.006	O-Ring - ABC 150	5 Pcs
8	204.58.003	Torch Body Abiplast Cut 150	1 Pc



Item Code	Item Name	MoQ
204.53.004	Abiplas Cut 150 at 6.0 m - Standard	1 Set

Jakarta Head Office :

Jl. Pangeran Jayakarta 141, Block II No. C 4 & 5, Jakarta 10730
Telephone : +62 - 21 - 600 8460
Fax : +62 - 21 - 624 4405, 649 0759
Tools & Power Tools Division : tools@bumi.info
Panel & Hand Tools Division : pht@bumi.info
Welding Machine Division : welding.machine@bumi.info
Welding Accessories Division : welding.accessories@bumi.info
Welding Consumable Division : welding.consumable@bumi.info
Retail Division : retail@bumi.info
Service Division : service.jkt@bumi.info

Surabaya Branch Office :

Jl. Saroni Jiwo No. 4 , Surabaya 60299
Telephone : +62 - 31 - 847 5608
Fax : +62 - 31 - 841 1736
Tools & Power Tools Division : tools.sby@bumi.info
Panel & Hand Tools Division : pht.sby@bumi.info
Welding Machine Division : welding.machine.sby@bumi.info
Welding Accessories Division : welding.accessories.sby@bumi.info
Welding Consumable Division : welding.consumable.sby@bumi.info
Retail Division : retail.sby@bumi.info
Service Division : service.sby@bumi.info

Semarang Branch Office :

Jl. Cendrawasih No. 8B
Semarang 50138
Telephone : +62 - 24 - 358 5809
Fax : +62 - 24 - 354 6278
Sales : bumi.smg@bumi.info
Retail : retail.smg@bumi.info
Service : service.smg@bumi.info

Balikpapan Branch Office :

Jl. Letkol Pol. H.M. Asnawi Arbain, Ruko Rubiz No. 39
Balikpapan Selatan 76115
Telephone : +62 - 542 - 771 728
Fax : +62 - 542 - 763 968
Sales : bumi.bpp@bumi.info
Retail : retail.bpp@bumi.info
Service : service.bpp@bumi.info

Bumi Distribution Center :

Jl. Raya Kamal No. 9, Unit C - Unit D,
Jakarta Barat 11820
Telephone : +62 - 21 - 555 8228



website : www.bumi.info



Facebook : [bumi.info jakarta](https://www.facebook.com/bumi.info.jakarta)
[bumi.info semarang](https://www.facebook.com/bumi.info.semarang)
[bumi.info surabaya](https://www.facebook.com/bumi.info.surabaya)
[bumi.info Balikpapan](https://www.facebook.com/bumi.info.balikpapan)



Youtube : [bumi.info](https://www.youtube.com/bumi.info)



Instagram : [bumi.info](https://www.instagram.com/bumi.info)



Linked-In : [bumi.info](https://www.linkedin.com/bumi.info)



Twitter : [bumi.info](https://twitter.com/bumi.info)