

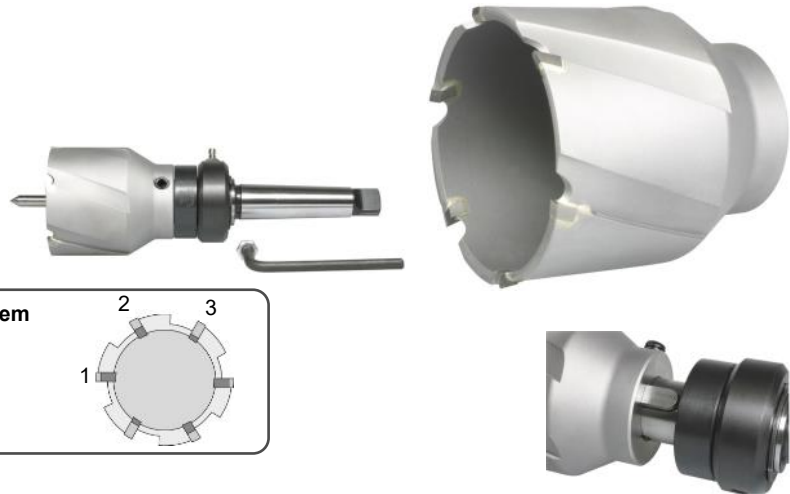

## Rotabest TCT AL depth 50 mm



### Main Applications

- Steel fabricators
- Shipyard
- Power plant
- Boiler

### Chip Breaker System

1. Pre Cutter
2. Middle Cutter
3. Post Cutter

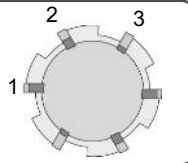

### Advantageous

- Suitable for all core drilling, pillar drilling and milling machines
- Heavy industry design with keyway and feather key
- Long term tests series have shown that this specialized design with keyway and feather key has proved outstanding compared to a standard 32 mm Weldon shank. Optimal containment of high torsion forces
- Chip breaker system : pre cutter, middle cutter and post cutter
- Required : tool holder with internal cooling
- Perfect cutting behavior, even at the first drill hole
- Excellent centering properties
- Low cutting pressure and low power use
- Vibration free working
- Chip distribution, no chip jamming
- Drilling depth can be reached in a single operation
- Drill core can be easily ejected

Item Code	Item Size	MoQ
209.03.001	Ø 51 mm	1 Pc
209.03.002	Ø 52 mm	1 Pc
209.03.003	Ø 53 mm	1 Pc
209.03.004	Ø 54 mm	1 Pc
209.03.005	Ø 55 mm	1 Pc
209.03.006	Ø 56 mm	1 Pc
209.03.007	Ø 57 mm	1 Pc
209.03.008	Ø 58 mm	1 Pc
209.03.009	Ø 59 mm	1 Pc
209.03.010	Ø 60 mm	1 Pc
209.03.011	Ø 61 mm	1 Pc
209.03.012	Ø 62 mm	1 Pc
209.03.013	Ø 63 mm	1 Pc
209.03.014	Ø 64 mm	1 Pc
209.03.015	Ø 65 mm	1 Pc
209.03.016	Ø 66 mm	1 Pc
209.03.017	Ø 67 mm	1 Pc
209.03.018	Ø 68 mm	1 Pc
209.03.019	Ø 69 mm	1 Pc
209.03.020	Ø 70 mm	1 Pc
209.03.021	Ø 71 mm	1 Pc
209.03.022	Ø 72 mm	1 Pc
209.03.023	Ø 73 mm	1 Pc
209.03.024	Ø 74 mm	1 Pc
209.03.025	Ø 75 mm	1 Pc
209.03.026	Ø 76 mm	1 Pc
209.03.027	Ø 77 mm	1 Pc
209.03.028	Ø 78 mm	1 Pc
209.03.029	Ø 79 mm	1 Pc
209.03.030	Ø 80 mm	1 Pc
209.03.031	Ø 81 mm	1 Pc
209.03.032	Ø 82 mm	1 Pc
209.03.033	Ø 83 mm	1 Pc
209.03.034	Ø 84 mm	1 Pc
209.03.035	Ø 85 mm	1 Pc
209.03.036	Ø 86 mm	1 Pc
209.03.037	Ø 87 mm	1 Pc

Item Code	Item Size	MoQ
209.03.038	Ø 88 mm	1 Pc
209.03.039	Ø 89 mm	1 Pc
209.03.040	Ø 90 mm	1 Pc
209.03.041	Ø 91 mm	1 Pc
209.03.042	Ø 92 mm	1 Pc
209.03.043	Ø 93 mm	1 Pc
209.03.044	Ø 94 mm	1 Pc
209.03.045	Ø 95 mm	1 Pc
209.03.046	Ø 96 mm	1 Pc
209.03.047	Ø 97 mm	1 Pc
209.03.048	Ø 98 mm	1 Pc
209.03.049	Ø 99 mm	1 Pc
209.03.050	Ø 100 mm	1 Pc

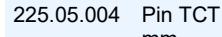

Item Code	Item Name	MoQ
-----------	-----------	-----

### Optional Accessories

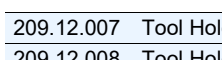
	209.09.003 Pin TCT 50 Ø 18 - 50 mm & AL 50 Ø 51 - 100 mm, 8 x 102 mm	1 Pc
	225.05.004 Pin TCT 50 Ø 18 - 50 mm , 7.98 x 108 mm	1 Pc

	209.12.007 Tool Holder AL-3	1 Pc
	209.12.008 Tool Holder AL-4	1 Pc

	208.25.010 Coolant Tank	1 Pc
--	-------------------------	------

	308.02.001 Coolant 2000 at 1 Liter	1 Pc
	308.02.002 Coolant 2000 at 5 Liter	1 Pc